



Idola SW-T 3.2

Reversible and split heat pumps with dc inverter compressor and integrated DHW storage

Full Inverter split heat pumps with low environmental impact R32 gas with low environmental impact. The split installation has the advantage of avoiding any problem of freezing in the outdoor unit, even at the coldest temperatures (**to -25°C**) and in the absence of power.

OMNIA SW-T 3.2 is a heat pump, for **heating and the production of domestic hot water**, designed for applications in small and medium-sized housing units.

Each of its components has been designed with the **renovation of existing heating systems** in mind and for the **replacement of boilers** and electric water heaters, ensuring the same comfort, with an efficient and environmentally friendly solution.

All the units meet the most extreme winter climate control requirements, in fact they can produce **hot water up to 65°C**, which makes them suitable for practically all heating systems.

The generators consist of an outdoor unit with the heart of the cooling circuit, from the compressor to the fan with the air side exchanger, which will be connected to the refrigerant gas pipes towards the indoor unit which, instead, contains the hub of the hydraulic circuit (complete with all system components) and the **100-liter DHW storage tank**.

The indoor unit is also equipped with two electrical integrations: **3kW for the heating system and 1.2 kW for DHW production**.

The new Full Inverter concept by Ferroli uses DC inverter modulations on the 3 main energy-intensive components of the machine, i.e. compressor, fan and pump. This makes it possible to modulate the power by finely tracking the thermal load and offering the user very high efficiencies and significant energy saving.

The Ferroli Full Inverter concept also makes it possible to reduce inrush currents, avoiding sudden changes in the grid and ensuring a longer service life for the components.

The quality of the components and production processes has made it possible to achieve one of the **lowest noise levels** among the units on the market today

The control system

The user interface is equipped with **Capsense** technology with a 2.8" graphic display, which allows the user to interact easily and simply. The interface on the machine communicates with the **Connect CRP** systems, which can manage **up to 8 thermostats** (7 **Connect CRP Zone** + 1 **Connect CRP**) divided into 2 zones, one direct and one mixed.

MODBUS PROTOCOL for smart management via possible external **BMS HEATING AND COOLING** with singular generator and heat pump. Full Inverter modulation makes it possible to maintain the desired setpoints, optimizing consumption for the user. The setting of climate curves (as standard) can improve comfort and further reduce consumption

DOMESTIC HOT WATER (DHW) PRODUCTION It activates when the DHW temperature probe goes below the DHW setpoint

ADDITIONAL ENERGY SOURCES (heating elements). The heat pump can activate these additional sources in Integration or Replacement, based on customizable parameters. In addition to these settings, the call can occur in an emergency, where the heat pump is faulty

PHOTOVOLTAIC AND GRID SMART GRID INPUTS The unit is equipped with 2 digital inputs (Smart Grid contacts) for managing an input from the photovoltaic system and from the electricity grid and optimizing consumption and bill costs

REMOTE CONTROL VIA APP Available for iOS and Android in combination with Connect CRP (optional)

DHW STORAGE TANK HEATING ELEMENT In DHW mode, the unit manages a heating element inserted in the storage tank as integration, anti-legionella function or as a reserve source, in case of a fault

FAST DHW A function to give priority to DHW production by activating all available energy sources, to bring the DHW storage tank to the setpoint in the shortest possible time

ANTI-LEGIONELLA FUNCTION For setting anti-legionella weekly cycles.

SILENT MODE Reduces compressor frequency and fan speed to reduce noise. 2 different levels are available, programmable in daily time bands (e.g. night)

ON/OFF from external contact. The unit can be activated and deactivated via an external contact (e.g. from a zone thermostat): in this case the operating mode will follow the controller settings

HEAT/COOL from external contacts. The unit can receive a summer/winter switching signal from outside (e.g. from the zone thermostat)

ECO Dedicated setpoint for "Eco" operation. Settable also for time bands

WEEKLY TIME PROGRAMMING The Connect CRP (optional) allows time programming for each day of the week by defining the mode (COOL/HEAT/DHW) and setpoint for each band

FROST PROTECTION with heat pump working in heating mode with circulating pump ON and possible electric booster

System code	System model
OXHM4SWD	IDOLA SW-T 3.2 04
OXHM6SWD	IDOLA SW-T 3.2 06
OXHM8SWD	IDOLA SW-T 3.2 08
OXHMASWD	IDOLA SW-T 3.2 10

2.8" GRAPHIC INTERFACE WITH CAPSENSE TECHNOLOGY

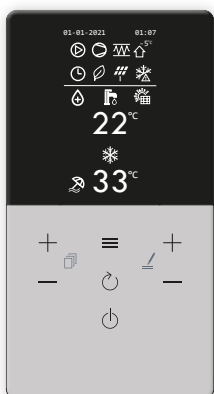

OUTDOOR UNIT TECHNICAL DATA			4	6	8	10
Low temperature seasonal efficiency (water produced 35°C)	ηs (%)		191	195	205	204
ErP class in heating	Class		A+++	A+++	A+++	A+++
Average temperature seasonal efficiency (water produced 55°C)	ηs (%)		129	138	131	136
ErP class in heating	Class		A++	A++	A++	A++
SCOOP low temperature (water produced 35°C)			4.85	4.95	5.21	5.19
SEER (water produced 7°C)			4.99	5.34	5.83	5.98
Electrical power supply	Vac / Hz		220-240 / 50			
Compressors / Cooling circuits / Type of exchanger	no.		1 / 1 / Finned coil			
No. and Type of fans			1 x Axial DC			
Type of refrigerant / GWP			R32 / GWP 675			
Factory refrigerant charge ***	Kg		1.5	1.65	1.84	1.84
Cooling lines (max. length / max. vertical difference) ***	m		30/20			
SWL - Sound power level in heating	A7W35	dB(A)	56	58	59	60
SWL - Sound power level in cooling *	A35W18	dB(A)	56	58	60	60
Max. current absorbed	A		12	14	16	17
Net weight	Kg		58		77	

INDOOR UNIT TECHNICAL DATA			4	6	8	10
Electrical power supply	Vac / Hz		220-240 / 50			
Heating system expansion vessel volume	liters		10			
Heating system max. pressure	bar		3			
Heating system plumbing connections			3/4" GAS M			
DHW plumbing connections			1/2" GAS M			
Liquid line cooling connections			3/8" SAE / f 9,52			
Gas line cooling connections			5/8" SAE / f 15,88			
DHW storage tank volume	liters		100			
System electric heater / DHW storage tank	kW		3 / 1,2			
DHW expansion vessel volume	liters		5			
DHW max. working pressure	bar		9			
SWL - indoor unit sound power level	dB(A)		39			
Net weight	Kg		95/103			

* SWL = Sound power levels, referred to 1x10⁻¹² W with unit operating under conditions: **A7W35** = source: air at 7°C d.b. 6°C w.b. / system: water at 30°C out 35°C. **A35W18** = source: air at 35°C d.b. / system: water at 23°C out 18°C. The Total sound power level in dB(A) is measured in accordance with ISO 9614. ** For combination with outdoor units models 4-6 a reduction from 3/8" SAE to 1/4" SAE for Ø 6.35 liquid line is supplied. *** The factory refrigerant charge allows a maximum cooling line length of 15 meters. It is possible to reach 30 meters with a charge integration during installation.

PERFORMANCE DATA			4	6	8	10
A7W35	Nominal heat output	kW	4,2	6,35	8,4	10
	Nominal absorbed power	kW	0,82	1,28	1,63	2,02
	COP	W/W	5,1	4,95	5,15	4,95
A7W45	Nominal heat output	kW	4,3	6,3	8,3	10
	Nominal absorbed power	kW	1,13	1,7	2,16	2,67
	COP	W/W	3,8	3,7	3,85	3,75
A35W18	Nominal cooling capacity	kW	4,5	6,5	8,3	9,9
	Nominal absorbed power	kW	0,82	1,35	1,64	2,18
	EER	W/W	5,5	4,8	5,05	4,55
A35W7	Nominal cooling capacity	kW	4,7	6,5	7,45	8,2
	Nominal absorbed power	kW	1,36	2,17	2,22	2,52
	EER	W/W	3,45	3	3,35	3,25

The values refer to units without possible options or accessories. Data declared according to EN 14511: **EER** (Energy Efficiency Ratio) = ratio of cooling capacity to absorbed power **COP** (Coefficient Of Performance) = ratio of heat output to absorbed power **A7W35** = source : air at 7°C d.b. 6°C w.b. / system : water at 30°C out 35°C **A7W45** = source : air at 7°C d.b. 6°C w.b. / system : water at 40°C out 45°C **A35W18** = source : air at 35°C d.b. / system : water at 23°C out 18°C **A35W7** = source : air at 35°C d.b. / system : water at 12°C out 7°C

	DESCRIPTION	CODE
	Connect CRP. Advanced remote control with chronothermostat function.	013069XD
	Connect CRP Zone. Zone thermostat with RF connection to Connect CRP	013055XD
	Plumbing connection kit with faucets (DHW inlet, system flow and return), pipes and fittings. Arranged for installation combined with the dirt separator and the polyphosphate doser.	012101X0
	Rubber anti-vibration kit for outdoor unit	2CP000ZF

	DESCRIPTION	CODE
	Spacer kit for generator replacement with wall mounts	016010X0
	Mount cover kit	016011X0
	PROTECTOR* Magnetic dirt separator filter kit supplied with shutoff valve	0YBP3BX0
	DOSAPLUS Double action polyphosphate/silicate dosing filter kit	0YBD0QX0

Operating limits

COOL MODE

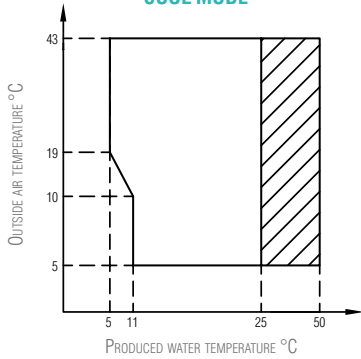

Operating range with heat pump with possible limitation and protection

HEAT MODE

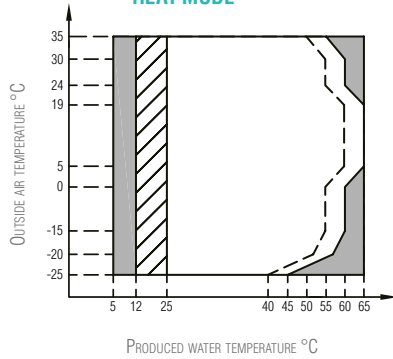

Operating range with heat pump with possible limitation and protection

With IBH (system electric heater) installed

Max. inlet water temperature line for heat pump operation

DHW MODE

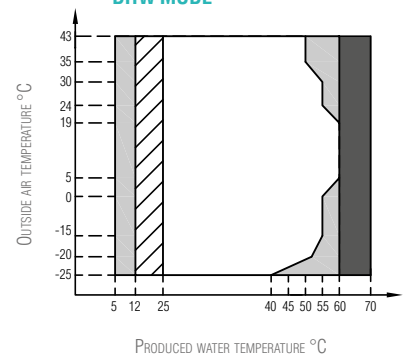

Operating range with heat pump with possible limitation and protection

With IBH (system electric heater) / TBH (DHW electric heater) installed

With TBH (DHW electric heater) installed

Minimum operating spaces (in mm)

INDOOR UNIT

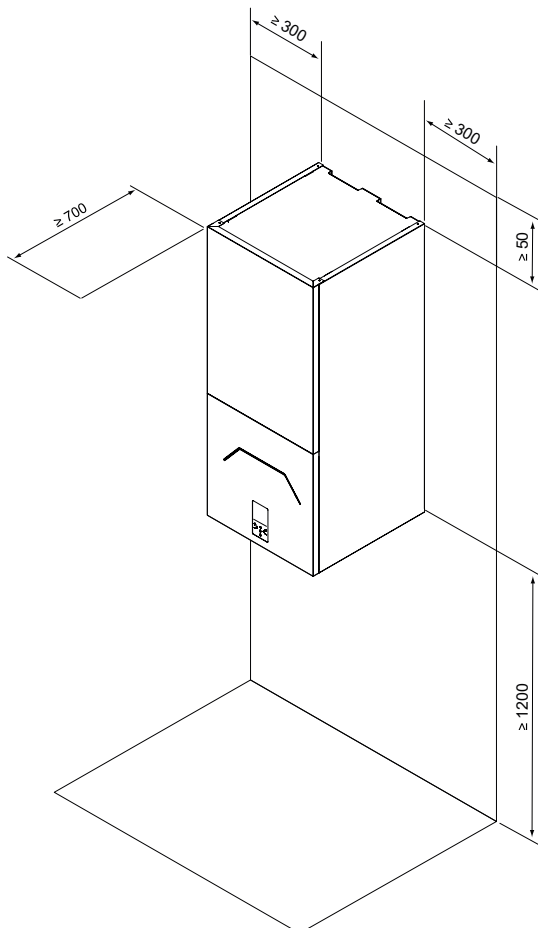

OUTDOOR UNIT

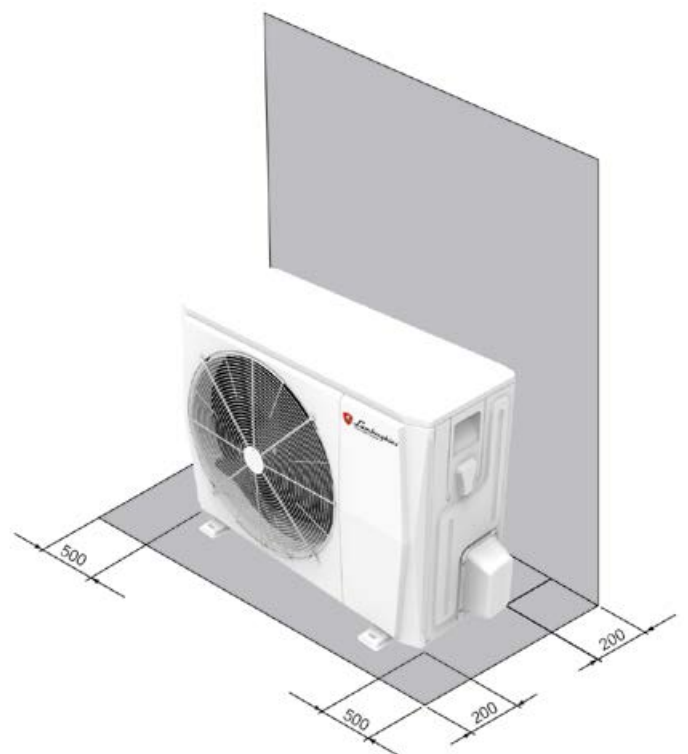

Indoor unit overall dimension (in mm)

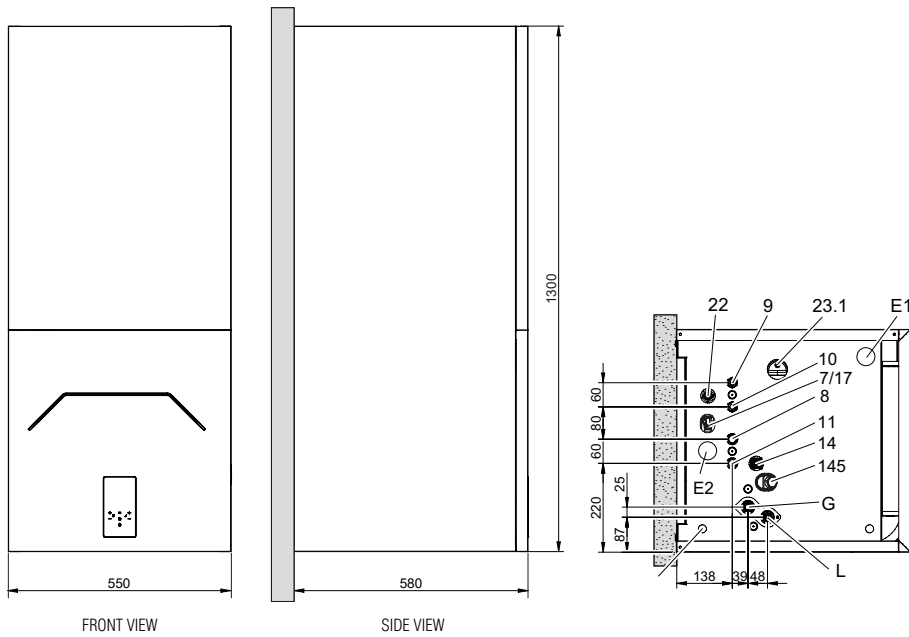

KEY

- 7 Water filling
 - 8 System outlet - Ø 3/4" M
 - 9 DHW outlet - Ø 1/2" M
 - 10 DHW inlet - Ø 1/2" M
 - 11 System inlet - Ø 3/4" M
 - 14 System safety valve with water drain faucet function
 - 17 Check valve
 - 22 DHW safety valve
 - 23.1 Access to the system expansion vessel filling valve
 - 145 Water pressure switch
 - E1 Cable gland for signal cables
 - E2 Cable gland for power cables
 - E3 Power cable
 - G Gas line - Ø 15.88 (5/8")
 - L* Liquid line - Ø 9.52 (3/8")
- * For combination with outdoor units models 4-6, a reduction from 3/8" SAE to 1/4" SAE is supplied for Ø 6.35 liquid line

Outdoor unit overall dimension (in mm)

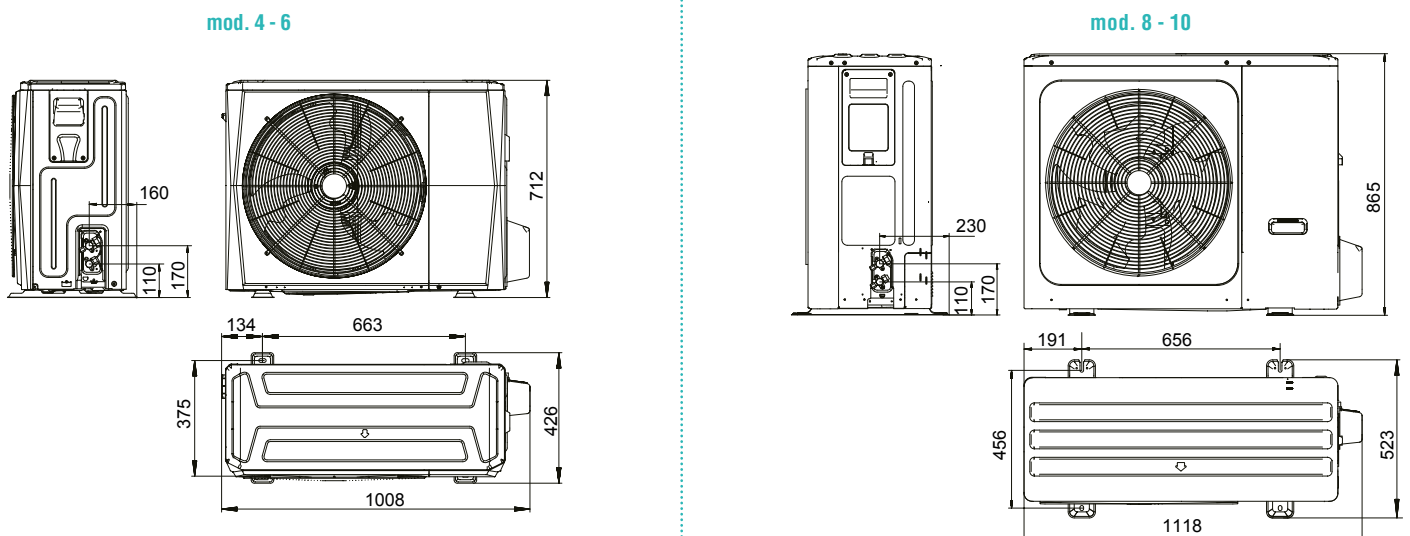

MODELS		4	6	8	10
Packing (WxHxD)	mm	1065x800x485		1190x970x560	
Packing weight	kg	65		94	