

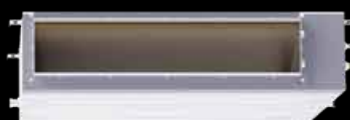

*Lamborghini*  
CALORECLIMA



## Smeraldo

Monosplit / Multisplit heat pump with DC inverter,  
in R32 for residential and commercial applications

# SMERALDO

## THE QUALITY AIR CONDITIONER AT THE RIGHT PRICE



Are you looking for a quality air conditioner at the right price? Take a look at **Smeraldo**, the latest split heat pump system by Lamborghini CaloreClima, in the monosplit and multisplit version, capable of satisfying all your requirements.

Smeraldo simply has everything. Thanks to the optimised cooling circuit and adjustment that regulates the compressor with DC inverter technology, these machines can accurately and promptly reach your temperature setpoints, for both heating and cooling. This means **less noise, maximum comfort and first-class efficiency**, resulting in less kilowatts per hour in your electricity bill. The Smeraldo monosplit versions, for example, never fall below class A\*\*.

They also use **R32** refrigerant, the more eco-sustainable gas that does not harm the ozone and has a GWP of about a third compared to the more commonly used R410A.

All Smeraldo appliances can be connected to your **Wi-Fi**, as standard, without expensive accessories. Moreover, the new Smeraldo air conditioners are **compatible** with the **“Amazon Alexa”** and **“Google Home”** voice assistants. Thanks to our **free App**, you can easily manage and program them remotely.

But that's not all, a **double filtration layer** and **cutting-edge treatment of the external coil** are included, ensuring long-term protection from the weather.

Carry on reading to learn more in the following pages.

# LET'S TAKE A LOOK AT SMERALDO

## HOW IT GUARANTEES YOUR WELL-BEING

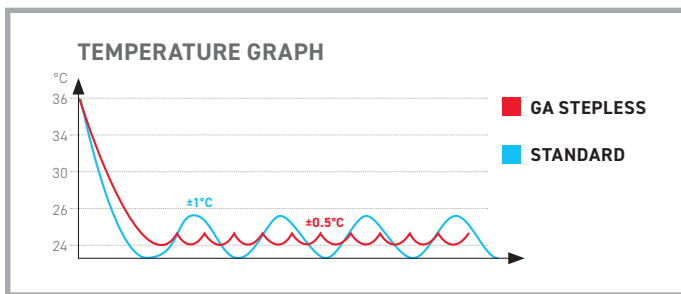
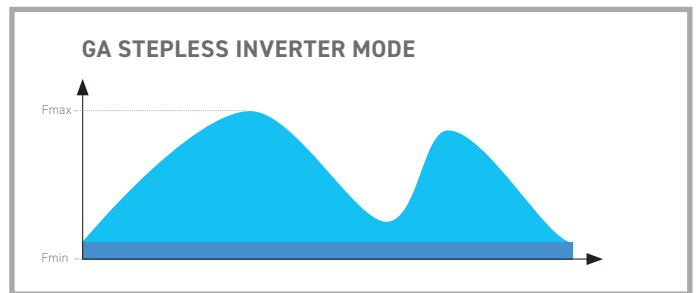
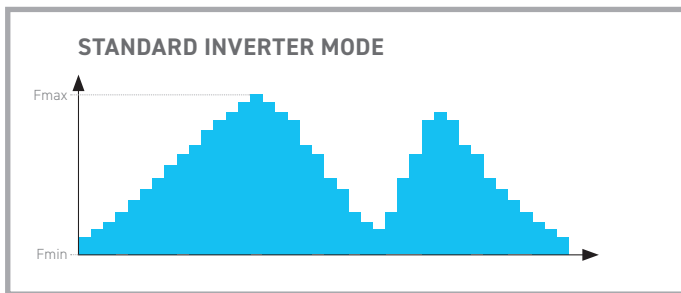

Thanks to Lamborghini CaloreClima's **GA Stepless Comfort** technology, the inverters can modulate with minimal frequency fluctuations, so small that some temperature fluctuations in the room will not be noticeable.

But that's not all, the units can also be used in **Boost** mode to reach the required temperatures in the shortest possible time. This may reduce the efficiency of the machines for brief periods, but will be very useful if you need to cool a room quickly.



The **i-Clean** function helps wash away dust, mould and grease that may settle on the heat exchanger, causing unpleasant odours.

The fan coil runs extra drying cycles, keeping surfaces clean.

**This function is available only for Smeraldo Mono models.**

# LET'S FIND OUT ABOUT...

## ALL THE BENEFITS OF SMERALDO

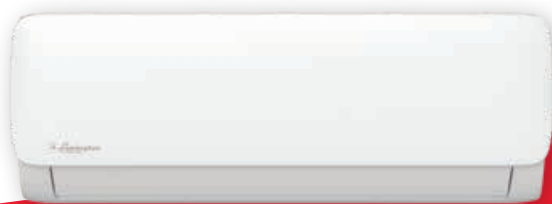

### SMERALDO

AVAILABLE IN THE MONO AND MULTI SPLIT VERSION, FOR ALL REQUIREMENTS

*Filtering*  
Q · U · A · D · R · U · P · L · E



Regarding air quality, Smeraldo air conditioners, in both Mono and Multi Split versions, feature a **quadruple level of filtration**, consisting of **“Cold Catalyst”, “Active Carbon”, “Silver Ion” and “Biohepa”** filters. In addition to this, Smeraldo is equipped with the new sanitising technology **“Super Ioniser”**.

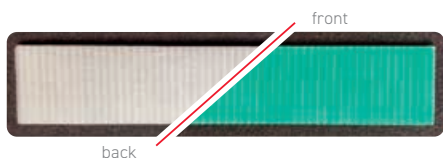
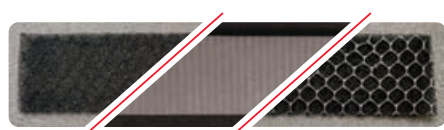

### 4 FILTERS: COLD CATALYST, ACTIVE CARBON, SILVER ION AND BIOHEPA

New four-layer filter technology that purifies the air and removes gases, odours, formaldehydes, pollutants, bacteria, viruses and fungi from it.

### NEW SUPER IONISER

New Ioniser that releases millions of ions to drastically reduce the presence of viruses and bacteria in the air.

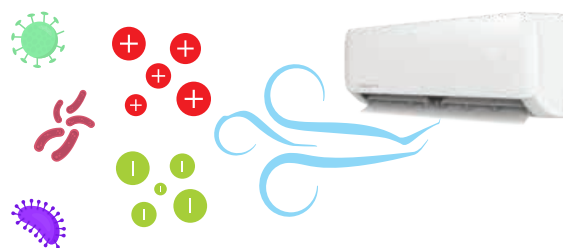













### IN ADDITION TO CONVENIENCE, WI-FI CONNECTIVITY AND VOICE COMMAND COMPATIBILITY ARE INCLUDED

With an unbeatable price, Smeraldo air conditioners guarantee **SEER** and **SCOP**; they can achieve an efficiency class of A\*\* in cooling mode and A\* in heating mode (for the typical average temperature band). All the appliances are also supplied with a **Wi-Fi** connection, thanks to which it is possible to connect remotely using the Lamborghini CaloreClima **App**. Moreover, the new range is now compatible with the **“Amazon Alexa”** and **“Google Home”** voice assistants. The remote control supplied (with a larger display as requested by our customers) can, of course, manage all of Smeraldo's functions. Moreover, the App also offers you the possibility of remote access together with the handy **Smart Diagnosis** function, allowing you to run up to 97 function tests on your air conditioner to check that it is working correctly and detect any (highly unlikely) problems.

# TECHNICAL DATA

## SMERALDO MONO VERSION

MODEL			09	12	18	24
Power supply		V-Ph-Hz	220/240 V - 1 phase - 50Hz			
Cooling power <sup>(1)</sup>	nominal	W	2,640	3,515	5,275	5,880
	min-max	W	1,025 ~ 3,225	1,375 ~ 4,310	3,390 ~ 5,900	2,110 ~ 8,205
Power absorbed in cooling	nominal	W	733	1,089	1,550	1,765
	min-max	W	80 ~ 1,100	120 ~ 1,650	560 ~ 2,050	420 ~ 3,200
Current absorbed in cooling	nominal	A	3.18	4.73	6.70	7.67
	min-max	A	0.35 ~ 4.78	0.5 ~ 7.2	2.4 ~ 9.0	1.8 ~ 13.9
EER ref. Standard EN14511 (nominal)			3.60	3.23	3.40	3.33
Cooling	SEER		7.40	7.00	7.00	6.40
	PdesignC	kW	2.80	3.60	5.30	7.00
	Class ErP					
Thermal power <sup>(2)</sup>	nominal	W	2,930	3,810	5,390	6,660
	min-max	W	820 ~ 3,370	1,070 ~ 4,380	3,100 ~ 5,850	1,555 ~ 8,205
Power absorbed in heating	nominal	W	771	1,027	1,436	1,771
	min-max	W	70 ~ 990	110 ~ 1,480	780 ~ 2,000	300 ~ 3,100
Current absorbed in heating	nominal	A	3.35	4.46	6.23	7.70
	min-max	A	0.32 ~ 4.32	0.5 ~ 6.4	3.4 ~ 8.7	1.3 ~ 13.5
COP ref. Standard EN14511 (nominal)			3.80	3.71	3.76	3.76
Heating Moderate climate zone	SCOP		4.10	4.20	4.00	4.00
	PdesignH	kW	2.50	2.50	4.20	4.90
	Class ErP					
	Tbiv / Tol	°C	-7 / -15	-7 / -15	-7 / -15	-7 / -15
Heating Warm climate zone	SCOP		5.30	5.50	5.10	5.10
	PdesignH	kW	2.50	2.50	4.50	5.30
	Class ErP					
	Tbiv / Tol	°C	2 / -15	2 / -15	2 / -15	2 / -15
Maximum power absorbed		W	2,150	2,150	2,500	3,700
Maximum current absorbed		A	10	10	13	19.0
Inrush current		A	Negligible thanks to inverter technology			
Indoor unit	Air flow rate (max-med-min)	m <sup>3</sup> /h	460 / 460 / 330	530 / 400 / 350	800 / 600 / 500	1,090 / 770 / 610
	Sound pressure <sup>(3)</sup> (max-med-min-slo)	dB(A)	37 / 32 / 22 / 20	37 / 32 / 22 / 21	41 / 37 / 31 / 20	46 / 37 / 34.5 / 21
	Sound pressure (max)	dB(A)	54	55	56	62.0
Outdoor unit	Air flow rate	m <sup>3</sup> /h	1,850	1,850	2,100	3,500
	Sound pressure <sup>(3)</sup>	dB(A)	55.5	55	57.0	60.0
	Sound power	dB(A)	62	62	65.0	67.0
Refrigerant gas	Type / GWP		R32 / 675			
	Load quantity	kg	0.60	0.65	1.10	1.45
Liquid / gas line connections		inches	1/4" - 3/8"	1/4" - 3/8"	1/4" - 1/2"	3/8" - 5/8"
Maximum length refrigeration lines		m	25	25	30	50
Maximum height difference		m	10	10	20	25

**(1)** External air temperature = 35°C D.B. • Room air temperature = 27°C D.B. / 19°C W.B. - **(2)** External air temperature = 7°C D.B. / 6°C W.B. • Room air temperature = 20°C D.B. - **(3)** Sound pressure measured at a distance of 1 m: E.U. in open area, I.U. in 100 m<sup>3</sup> room with 0.5 second reverberation time

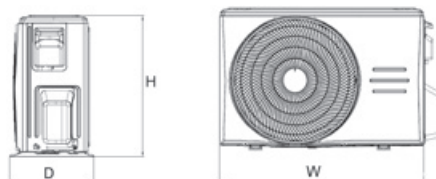









MODEL	W mm	H mm	D mm	Weight kg
9	726	291	210	8.0
12	835	295	208	8.7
18	969	320	241	11.2
24	1083	336	244	13.6

MODEL	W mm	H mm	D mm	Weight kg
9	720	495	270	23.5
12	720	495	270	23.7
18	805	554	330	32.8
24	890	673	342	43.9

# TECHNICAL DATA

## SMERALDO MULTI VERSION

OUTDOOR UNIT*			18-2	27-3	28-4
Power supply		V-Ph-Hz	220/240 V - 1 phase - 50Hz		
Cooling power <sup>(1)</sup>	nominal	W	5,275	7,915	8,205
	min-max	W	2,225 ~ 5,570	3,025 ~ 8,500	2,490 ~ 10,255
Power absorbed in cooling	nominal	W	1,635	2,450	2,500
	min-max	W	690 ~ 2,000	230 ~ 3,250	150 ~ 3,340
Current absorbed in cooling	nominal	A	7.1	11.2	10.9
	min-max	A	3.2 ~ 9.0	2.1 ~ 14.7	1.3 ~ 14.5
EER ref. Standard EN14511 (nominal)			3.23	3.23	3.23
Cooling	SEER		6.1	6.1	7
	PdesignC	kW	5.3	7.9	8.2
	Class ErP				
Thermal power <sup>(2)</sup>	nominal	W	5,570	8,205	8,790
	min-max	W	2,340 ~ 5,625	2,200 ~ 8,500	1,605 ~ 10,140
Power absorbed in heating	nominal	W	1,500	2,210	2,400
	min-max	W	600 ~ 1,780	330 ~ 2,960	280 ~ 3,200
Current absorbed in heating	nominal	A	6.6	10.1	10.4
	min-max	A	2.80 ~ 7.95	2.6 ~ 13.5	1.98 ~ 14.0
COP ref. Standard EN14511 (nominal)			3.71	3.71	3.71
Heating Moderate climate zone	SCOP		4.0	4.0	4.0
	PdesignH	kW	4.5	5.7	6.8
	Class ErP				
	Tbiv / Tol	°C	-7 / -15	-7 / -15	-7 / -15
Heating Warm climate zone	SCOP		5.1	5.1	5.1
	PdesignH	kW	5	6	6.8
	Class ErP				
	Tbiv / Tol	°C	2 / -15	2 / -15	2 / -15
Maximum power absorbed		W	3,050	4,100	4,150
Maximum current absorbed		A	13	18	19
Inrush current		A	Negligible thanks to inverter technology		
Outdoor unit	Air flow rate	m <sup>3</sup> /h	2,100	3,000	3,800
	Sound pressure <sup>(3)</sup>	dB(A)	54	55	63.0
	Sound power	dB(A)	65	68	68
Refrigerant gas	Type / GWP		R32 /675		
	Load quantity	kg	1.25	1.85	2.1

INDOOR UNIT			9	12	18
Cooling performance		W	2,640	3,515	5,275
Thermal performance		W	2,930	3,810	5,570
Air flow rate (max-med-min)		m <sup>3</sup> /h	520 / 460 / 330	530 / 400 / 350	800 / 600 / 500
Sound pressure (max-med-min-slo)		dB(A)	37 / 32 / 22 / 20	37 / 32 / 22 / 21	41 / 37 / 31 / 20
Sound pressure (max)		dB(A)	54	56	56
Liquid / gas line connections		inches	1/4" - 3/8"	1/4" - 3/8"	1/4" - 1/2"

(1) External air temperature = 35°C D.B. • Room air temperature = 27°C D.B. / 19°C W.B. - (2) External air temperature = 7°C D.B. / 6°C W.B. • Room air temperature = 20°C D.B. - (3) Sound pressure measured at a distance of 1 m: E.U. in open area, I.U. in 100 m<sup>3</sup> room with 0.5 second reverberation time \* Nominal data, check combinations on the following pages

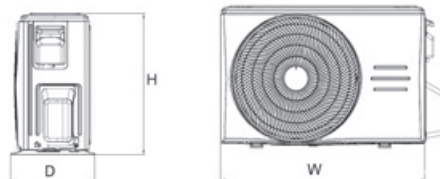

MODEL	W mm	H mm	D mm	Weight kg
9	726	291	210	8.0
12	835	295	208	8.7
18	969	320	241	11.2

MODEL	W mm	H mm	D mm	Weight kg
18-2	805	554	330	35.0
27-3	890	673	342	48.0
28-4	946	810	410	62.1

# FEATURES

## LIMITS - POSSIBLE COMBINATIONS

### FIELD OF APPLICATION

OPERATING MODE	PARAMETER		INDOOR SIDE	OUTDOOR SIDE
Cooling	Input air max/min temperature (B.S.)	°C	32 / 17	50 / -15
Heating	Input air max/min temperature (B.S.)	°C	30 / 0	24 / -15
All	Power voltage / frequency	V	230±10% / 50±2	

### LIMITS ON LENGTH AND HEIGHT DIFFERENCE OF COOLING PIPES

The length of the cooling pipes between the indoor and outdoor units must be the shortest possible and is, in any case, limited by the maximum values in height difference between the two units.

With the decrease in the difference in height between the units (H1,H2) and the length of the pipes (L), the load loss will be limited, thus increasing the overall performance of the machine. Observe the limits indicated in the following tables.

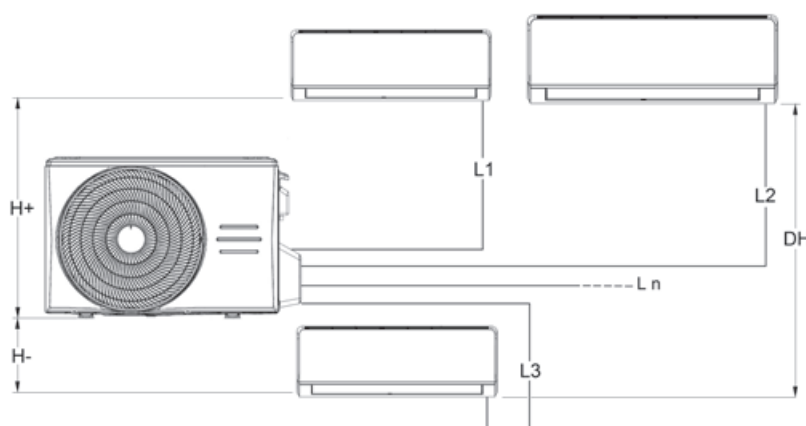

OUTDOOR UNIT			18-2		27-3			28-4		
Diameter	Liquid	"	1/4"	1/4"	1/4"	1/4"	1/4"	1/4"	1/4"	1/4"
	Gas	"	3/8"	3/8"	3/8"	3/8"	3/8"	3/8"	1/2"	1/2"
Tot. maximum length		m	40		60		80			
Maximum length single unit		m	25		30		35			
Maximum height difference	H+	m	15		15		15			
	H-	m	15		15		15			
	DH	m	10		10		10			
Total maximum length of pipes with standard load		m	7.5		7.5		7.5			
Additional quantity of refrigerant per metre		g/m	12	12	12	12	12	12	12	24

### TABLE OF POSSIBLE COMBINATIONS

OUTDOOR UNIT	INDOOR UNIT CONNECTED			
	1	2	3	4
18-2	9K	9K+9K	-	not included
	12K	9K+12K	-	
	18K	12K+12K	-	
27-3	9K	9K+9K	12K+12K	not included
	12K	9K+12K	12K+18K	
	18K	9K+18K	-	
28-4	9K	9K+9K	12K+12K	9K+9K+9K
	12K	9K+12K	12K+18K	9K+9K+12K
	18K	9K+18K	18K+18K	9K+9K+18K

**NB:**

- combinations for which the total power required by the indoor units is compatible with the nominal power of the outdoor unit.
- combinations for which the total power required by the indoor units is higher than the nominal power of the outdoor unit. In the event of a simultaneous request for power by all the units connected, the power available for the individual units will be in line with the indications given in the previous table.

# PERFORMANCE IN COOLING MODE

## SUMMARY TABLE

EU	IU	Combination	Partial capacity (kW)				Total capacity in cooling (kW)			Power absorbed Total (kW)			Current absorbed Total (A)			EER	SEER	Energy class
			Room				Min	Nom	Max	Min	Nom	Max	Min	Nom	Max	Nom		
			A	B	C	D												
18-2	1	9	2.50	—	—	—	1.43	2.50	3.20	0.35	0.75	0.93	1.52	3.24	4.06	3.35	—	—
		12	3.50	—	—	—	1.43	3.50	3.90	0.35	1.08	1.29	1.52	4.68	5.62	3.25	—	—
	2	9+9	2.65	2.65	—	—	2.12	5.30	6.41	0.54	1.64	2.05	2.35	7.13	8.92	3.23	6.1	
		9+12	2.27	3.03	—	—	2.12	5.30	6.41	0.54	1.64	2.05	2.35	7.13	8.92	3.23	6.1	
		12+12	2.65	2.65	—	—	2.12	5.30	6.41	0.54	1.64	2.05	2.35	7.13	8.92	3.23	6.1	
27.3	2	9+9	2.65	2.65	—	—	2.21	5.30	7.11	0.64	1.64	2.45	2.76	7.13	10.63	3.23	5.6	
		9+12	2.57	3.43	—	—	2.21	6.00	7.51	0.64	1.86	2.57	2.76	8.08	11.17	3.23	5.6	
		9+18	2.27	4.53	—	—	2.21	6.80	7.90	0.64	2.09	2.69	2.76	9.10	11.70	3.25	5.6	
		12+12	3.15	3.15	—	—	2.21	6.30	7.66	0.64	1.94	2.64	2.76	8.45	11.48	3.24	5.6	
		12+18	2.72	4.08	—	—	2.21	6.80	7.90	0.64	2.09	2.69	2.76	9.10	11.70	3.25	5.6	
	3	9+9+9	2.63	2.63	2.63	—	2.77	7.90	8.69	0.76	2.45	2.91	3.30	10.63	12.65	3.23	6.1	
		9+9+12	2.37	2.37	3.16	—	2.77	7.90	8.69	0.76	2.45	2.91	3.30	10.63	12.65	3.23	6.1	
		9+12+12	2.15	2.87	2.87	—	2.77	7.90	8.69	0.76	2.45	2.91	3.30	10.63	12.65	3.23	6.1	
		12+12+12	2.63	2.63	2.63	—	2.77	7.90	8.69	0.76	2.45	2.91	3.30	10.63	12.65	3.23	6.1	
		9+9+18	2.37	2.37	3.16	—	2.77	7.90	8.69	0.76	2.45	2.91	3.30	10.63	12.65	3.23	6.1	
28.4	2	9+9	2.65	2.65	—	—	2.05	5.30	6.81	0.63	1.64	2.28	2.76	7.13	9.93	3.23	5.1	
		9+12	2.57	3.43	—	—	2.05	6.00	6.97	0.63	1.86	2.41	2.76	8.08	10.49	3.23	5.1	
		9+18	2.43	4.87	—	—	2.05	7.30	7.54	0.63	2.26	2.79	2.76	9.83	12.14	3.23	5.1	
		12+12	3.25	3.25	—	—	2.05	6.50	7.38	0.63	2.01	2.49	2.76	8.75	10.82	3.23	5.1	
		12+18	2.92	4.38	—	—	2.05	7.30	7.54	0.63	2.26	2.79	2.76	9.83	12.14	3.23	5.1	
		18+18	3.75	3.75	—	—	2.05	7.50	7.54	0.63	2.32	2.79	2.76	10.10	12.14	3.23	5.1	
	3	9+9+9	2.37	2.37	2.37	—	2.62	7.10	8.45	0.76	2.20	2.94	3.31	9.56	12.80	3.23	5.6	
		9+9+12	2.34	2.34	3.12	—	2.62	7.80	8.45	0.76	2.41	2.94	3.31	10.50	12.80	3.23	5.6	
		9+9+18	1.95	1.95	3.90	—	2.62	7.80	8.45	0.76	2.41	2.94	3.31	10.50	12.80	3.23	5.6	
		9+12+12	2.13	2.84	2.84	—	2.62	7.80	8.45	0.76	2.41	2.94	3.31	10.50	12.80	3.23	5.6	
		9+12+18	1.80	2.40	3.60	—	2.62	7.80	8.45	0.76	2.41	2.94	3.31	10.50	12.80	3.23	5.6	
		12+12+12	2.60	2.60	2.60	—	2.62	7.80	8.45	0.76	2.41	2.94	3.31	10.50	12.80	3.23	5.6	
	4	9+9+9+9	2.05	2.05	2.05	2.05	2.87	8.20	9.92	0.86	2.54	3.17	3.75	11.04	13.80	3.23	7.0	
		9+9+9+12	1.89	1.89	1.89	2.52	2.87	8.20	9.92	0.86	2.54	3.17	3.75	11.04	13.80	3.23	7.0	

# PERFORMANCE IN HEATING MODE

## SUMMARY TABLE

EU	IU	Combination	Partial capacity (kW)				Total capacity in heating (kW)			Power absorbed Total (kW)			Current absorbed Total (A)			COP	SCOP	Energy class
			Room				Min	Nom	Max	Min	Nom	Max	Min	Nom	Max	Nom		
			A	B	C	D												
18-2	1	9	3.00	–	–	–	1.56	3.00	3.63	0.32	0.80	1.00	1.39	3.48	4.35	3.75	–	–
		12	3.80	–	–	–	1.56	3.80	4.60	0.32	1.02	1.23	1.39	4.45	5.34	3.71	–	–
	2	9+9	2.79	2.79	–	–	2.23	5.57	6.68	0.51	1.50	1.88	2.22	6.53	8.16	3.71	4.0	
		9+12	2.40	3.20	–	–	2.23	5.60	6.68	0.51	1.51	1.88	2.22	6.56	8.16	3.71	4.0	
		12+12	2.80	2.80	–	–	2.23	5.60	6.96	0.51	1.51	1.88	2.22	6.56	8.16	3.71	4.0	
27-3	2	9+9	3.00	3.00	–	–	2.30	6.00	7.38	0.57	1.62	2.21	2.50	7.03	9.61	3.71	3.8	
		9+12	2.70	3.60	–	–	2.30	6.30	7.79	0.57	1.70	2.32	2.50	7.38	10.09	3.71	3.8	
		9+18	2.33	4.67	–	–	2.30	7.00	8.20	0.57	1.89	2.43	2.50	8.20	10.57	3.71	3.8	
		12+12	3.25	3.25	–	–	2.30	6.50	7.95	0.57	1.75	2.39	2.50	7.62	10.38	3.71	3.8	
		12+18	2.80	4.20	–	–	2.30	7.00	8.20	0.57	1.89	2.43	2.50	8.20	10.57	3.71	3.8	
	3	9+9+9	2.73	2.73	2.73	–	2.87	8.20	9.84	0.69	2.21	2.76	2.98	9.61	12.01	3.71	4.0	
		9+9+12	2.49	2.49	3.32	–	2.87	8.30	9.84	0.69	2.24	2.76	2.98	9.73	12.01	3.71	4.0	
		9+12+12	2.26	3.02	3.02	–	2.87	8.30	9.84	0.69	2.24	2.76	2.98	9.73	12.01	3.71	4.0	
		12+12+12	2.77	2.77	2.77	–	2.87	8.30	9.84	0.69	2.24	2.76	2.98	9.73	12.01	3.71	4.0	
		9+9+18	2.26	3.02	3.02	–	2.87	8.30	9.84	0.69	2.24	2.76	2.98	9.73	12.01	3.71	4.0	
28-4	2	9+9	3.00	3.00	–	–	2.20	6.00	7.30	0.59	1.62	2.13	2.58	7.03	9.28	3.71	3.4	
		9+12	3.00	4.00	–	–	2.20	7.00	7.48	0.59	1.89	2.25	2.58	8.20	9.80	3.71	3.4	
		9+18	2.63	5.27	–	–	2.20	7.90	8.10	0.59	2.13	2.61	2.58	9.26	11.34	3.71	3.4	
		12+12	3.75	3.75	–	–	2.20	7.50	7.92	0.59	2.02	2.32	2.58	8.79	10.11	3.71	3.4	
		12+18	3.20	4.80	–	–	2.20	8.00	8.10	0.59	2.16	2.61	2.58	9.38	11.34	3.71	3.4	
		18+18	4.00	4.00	–	–	2.20	8.00	8.10	0.59	2.16	2.61	2.58	9.38	11.34	3.71	3.4	
	3	9+9+9	2.87	2.87	2.87	–	2.82	8.60	9.06	0.71	2.32	2.75	3.09	10.08	11.96	3.71	3.5	
		9+9+12	2.58	2.58	3.44	–	2.82	8.60	9.06	0.71	2.32	2.75	3.09	10.08	11.96	3.71	3.5	
		9+9+18	2.15	2.15	4.30	–	2.82	8.60	9.06	0.71	2.32	2.75	3.09	10.08	11.96	3.71	3.5	
		9+12+12	2.35	3.13	3.13	–	2.82	8.60	9.06	0.71	2.32	2.75	3.09	10.08	11.96	3.71	3.5	
		9+12+18	1.98	2.65	3.97	–	2.82	8.60	9.06	0.71	2.32	2.75	3.09	10.08	11.96	3.71	3.5	
		12+12+12	2.87	2.87	2.87	–	2.82	8.60	9.06	0.71	2.32	2.75	3.09	10.08	11.96	3.71	3.5	
	4	9+9+9+9	2.23	2.23	2.23	2.2	3.08	8.90	10.65	0.81	2.40	2.96	3.51	10.43	12.89	3.71	4.0	
		9+9+9+12	2.10	2.10	2.10	2.8	3.08	9.10	10.65	0.81	2.45	2.96	3.51	10.66	12.89	3.71	4.0	

# BUT WHAT IS R32?

## WHY IS IT CONSIDERED ENVIRONMENTALLY FRIENDLY?

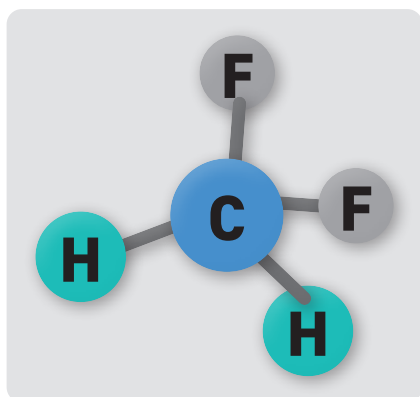

**DI-FLUORO-METHANE**

i.e.  
**CH<sub>2</sub>F<sub>2</sub>**

It is no longer a question of the hole in the ozone. R11, R12 and R22 have been banned for years now.

All new refrigerants must have **ODP** (Ozone Depletion Potential, i.e. the potential damage that the gas can cause to the ozone layer) must be nil, equal to zero.

We now talk about **GWP**.

GWP is the acronym for **Global Warming Potential** and indicates the potential impact that a refrigerant gas could have if it was released into the environment.

This allows the impact of 1kg of gas to be compared with 1 kg of CO<sub>2</sub>, over a period of 100 years.

For example, R410A has a GWP of 2,088. This basically means that 1 kg of R410A has the same impact as 2,088 kg of CO<sub>2</sub> (i.e. the equivalent of over 2 tons of CO<sub>2</sub>).

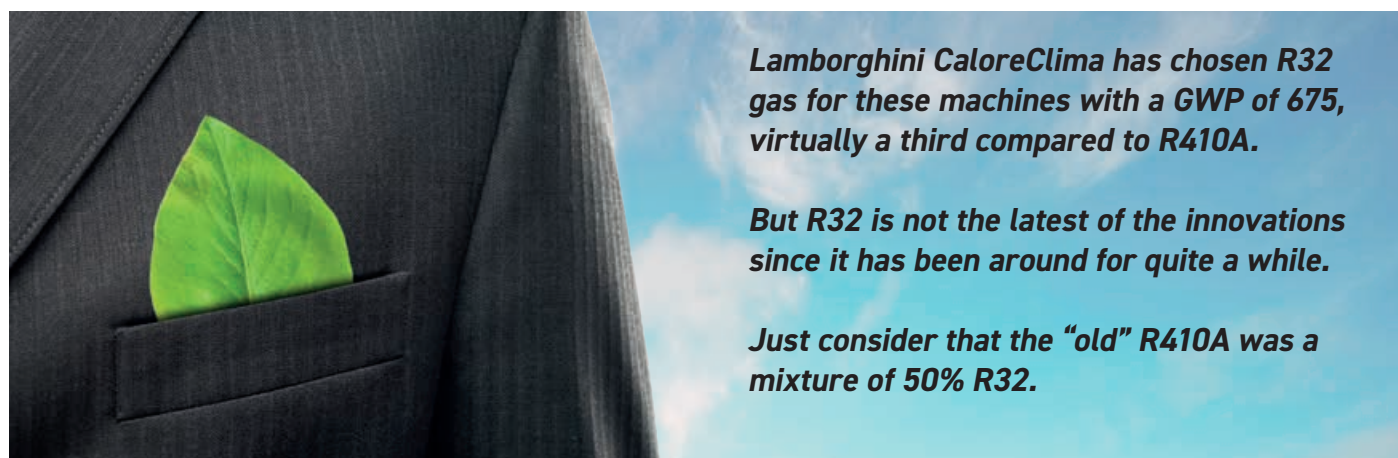

**R32** offers many benefits on small-medium power machines. It IS a gas with similar features to R410A, but with even **better thermodynamic properties!**

When comparing the two gases on machines of a similar construction (compressors of equivalent power and similar exchange surfaces), R32 allows you to achieve the same capacities, **but with greater efficiency and a reduced refrigerant load!**

This means using less gas with a lower GWP. In practical terms, we are not far wrong by stating that R32 leads to a **reduction of about 75% of emissions**, compare to the same machine with R410A.

## BUT WILL **R32** BE THE GAS OF THE FUTURE?

We have no problem in telling you no. We believe that R32 is an interim gas, but currently it is one of the best compromises in terms of performance and environmental impact. There are lots of other alternatives being developed, including natural ones.

**Lamborghini CaloreClima is also leading the way in this and we will let you know about any developments on the market.**

# SMERALDO - COMMERCIAL APPLICATION

## THE IDEAL SOLUTION FOR COMMERCIAL APPLICATIONS

Lamborghini CaloreClima's Smeraldo C commercial range includes a wide range of outdoor units (from 3.5 kW up to 15 kW) with axial fan, combinable with different types of indoor units: cassette, ducted, floor-ceiling and floor-standing units.



# SMERALDO C

## EXTERNAL UNIT



- The units all incorporate a Full DC Inverter compressor, which together with the special design of the fan and the latest generation inverter control allows the unit to achieve high performance and low noise levels
- Refrigerant flow control using an electronic expansion valve
- Single-phase power supply (models 12-18-24-30-36-42-48) and three-phase (models 36T-48T-55T)
- The units also have Golden Fin coils (anti-corrosion treatment) which extends the useful life of the equipment
- Furthermore It has WIFI communication, which allows optional control of the equipment through a smartphone or tablet via the own APP
- The outdoor unit has been designed with a single fan in all models, resulting in a unit of reduced dimensions, with a height of less than 1m, which facilitates its architectural integration into the building.
- Maximum piping length: 25-30m for models up to 18, 50m for models 24 and 30, and 75m for models 36-50



MODEL		12	18	24	30	36	36T	42	48	48T	55T	
Power supply	V / Hz / Ph	220-240V / 1Ph / 50Hz					380-415V / 3Ph / 50Hz		220-240V / 1Ph / 50Hz		380-415V / 3Ph / 50Hz	
Max input consumption	W	1850	2950	3700	4500	5000	5000	5000	7300	7300	7500	
Max current	A	9	13.5	19	20	22.5	10	22.5	32	14	14	
Compressor type		Rotary										
Outdoor air flow (Hi)		2200	2100	3500	3800	4000	4000	4000	5600	5600	5600	
Dimension (W*D*H)	mm	765 x 303 x 555	805 x 330 x 554	890 x 342 x 673	946 x 410 x 810	946 x 410 x 810	946 x 410 x 810	946 x 410 x 810	980 x 415 x 975	980 x 415 x 975	980 x 415 x 975	
Packing (W*D*H)	mm	887 x 337 x 610	915 x 370 x 615	995 x 398 x 740	1090 x 500 x 885	1090 x 500 x 885	1090 x 500 x 885	1090 x 500 x 885	1145 x 500 x 1080	1145 x 500 x 1080	1145 x 500 x 1080	
Net / Gross weight	Kg	26.6 / 29	32.5 / 35.2	41.9 / 45.2	51 / 55.7	66.9 / 71.5	80.5 / 85	71.0 / 75.0	82.5 / 97	90 / 105	92 / 107	
Refrigerant type		R32	R32	R32	R32	R32	R32	R32	R32	R32	R32	
Refrigerant GWP		675	675	675	675	675	675	675	675	675	675	
Refrigerant	Kg	0.71	1.15	1.4	1.8	2.4	2.4	2.8	2.9	2.9	3.2	
Liquid side / Gas side	mm (inch)	6.35 (1/4) / 9.52 (3/8)		6.35 (1/4) / 12.7 (1/2)		9.52 (3/8) / 15.9 (5/8)						
Max refrigerant pipe length	m	25	30	50	50	75	75	75	75	75	75	
Max difference in level	m	10	20	25	25	30	30	30	30	30	30	
Outdoor temp. in Cooling	°C	-15 ~ 50										
Outdoor temp. in Heating	°C	-20 ~ 24										

NOTE: The above design and specifications are subject to change without prior notice for product improvement.

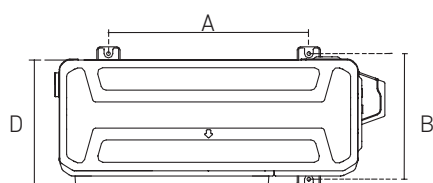
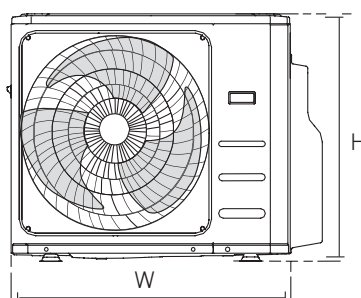

MODEL		W	H	D	A	B
12	mm	765	555	303	452	286
18	mm	805	554	330	511	317
24	mm	890	673	342	663	348
30-36-36T-42	mm	946	810	410	673	403
48-48T-55T	mm	980	975	415	616	397

# SMERALDO C

## CASSETTE INDOOR UNIT



models 12-18



models 24-55T



**The new cassette is perfect to integrate in any ceiling thanks to reduced dimensions**











- Cassette internal unit with reduced height
- Golden Fin protection in coil
- DC Inverter fan, to obtain high efficiency and reduced sound level
- 360° outlet air flow for better temperature distribution in the room space
- Integrated condensate drainage pump
- Arrangement for renewal air inlet or intake in adjacent room by canalization
- Infrared remote control as standard with a large display for complete control of the unit (wired remote control available as accessory)
- WIFI connection available. Possibility of controlling the unit via APP



<b>R32 GAS</b> 	<b>WIFI+APP AVAILABLE</b> 	<b>CONDENSATE PUMP</b> 	<b>REDUCED HEIGHT</b> 	<b>EXTERNAL AIR SUPPLY</b> 	<b>360° OUTLET AIR FLOW</b> 
--------------------	-------------------------------	----------------------------	---------------------------	--------------------------------	---------------------------------

# SMERALDO C













## CASSETTE INDOOR UNIT

MODEL			12	18	24	30	36	
Cooling	Pdesignc	kW	3.5	5.3	7.1	8.8	10.5	
	SEER	W/W	6.8	6.5	6.3	6.6	6.7	
	Energy Efficiency Class							
Heating (Average)	Pdesignh	kW	2.7	4.2	6.2	7.7	8.5	
	SCOP	W/W	4.1	4.1	4.1	4.2	4.0	
	Energy Efficiency Class							
	Tbiv	°C	-7	-7	-7	-7	-7	
Heating (Warmer)	Pdesignh	kW	3.3	5.3	6.3	7.8	10.1	
	SCOP	W/W	5.1	5.1	5.4	5.1	5.1	
	Energy Efficiency Class							
	Tbiv	°C	2	2	2	2	2	
Tol	°C	-15	-15	-15	-15	-15		
Power supply - Indoor	V, Hz, Ph	220-240V, 1 Ph, 50Hz						
Power supply - Outdoor	V, Hz, Ph	220-240V, 1Ph, 50Hz						
Cooling	Capacity	Btu/h	12000 (2900~14200)	18000 (9900~20000)	22180 (11250~27000)	30000 (7600~32000)	33956 (9200~39000)	
	Capacity	kW	3.52 (0.85~4.16)	5.28 (2.90~5.59)	6.50 (3.29~7.91)	8.79 (2.23~9.38)	9.95 (2.70~11.43)	
	Input	W	1015 (160~1450)	1550 (720~2040)	2000 (780~2750)	2720 (190~3000)	2989 (900~4200)	
	Current	A	4.5 (1.3~6.4)	6.9 (3.2~9.0)	8.8 (4.2~12)	11.8 (2.0~13.0)	17.5 (4.2~18.5)	
	EER	W/W	3.47	3.40	3.25	3.23	3.33	
Heating	Capacity	Btu/h	13000 (1600~14800)	18200 (8100~21500)	26000 (9500~29000)	32000 (9200~33200)	38000 (9500~42000)	
	Capacity	kW	3.81 (0.47~4.34)	5.33 (2.37~6.10)	7.62 (2.79~8.50)	9.38 (2.70~9.73)	11.14 (2.78~12.30)	
	Input	W	1020 (125~1390)	1420 (700~1950)	1900 (610~2300)	2450 (430~2550)	3000 (800~3950)	
	Current	A	4.5 (1.1~6.2)	6.0 (3.1~8.6)	8.5 (3.6~10.1)	11.0 (3.0~11.5)	13.5 (3.5~17.5)	
	COP	W/W	3.74	3.76	4.01	3.83	3.71	
Indoor air flow (Hi/Mi/Lo)	m³/h	620/520/330	660/540/300	1247/1118/992	1700/1530/1300	1700/1530/1300		
Indoor sound pressure level (Hi/Mi/Lo/Silent)	dB(A)	42/38.5/31.5/25.5	44/41/31.5/25	45/42.5/37/27.5	50.5/48/46/40	51/48/46/40		
Indoor sound power level (Hi)	dB(A)	55	59	59	63	63		
Outdoor sound pressure level (Hi)	dB(A)	57	58	60	62	63		
Outdoor sound power level (Hi)	dB(A)	62	65	68	70	70		
Dimension (WxDxH) (body)	mm	570x570x245	570x570x245	830x830x205	830x830x245	830x830x245		
Packing (WxDxH) (body)	mm	715x640x295	715x640x295	910x910x250	910x910x290	910x910x290		
Dimension (WxDxH) (panel)	mm	620x620x50	620x620x50	950x950x55	950x950x55	950x950x55		
Packing (WxDxH) (panel)	mm	715x700x115	715x700x115	1035x1035x90	1035x1035x90	1035x1035x90		
Net / Gross weight (body)	kg	16.1 / 18.8	16.2 / 19	21.6 / 25.4	24.6 / 28.6	27.2 / 31.2		
Net / Gross weight	kg	2.7 / 4.3	2.7 / 4.3	6 / 9	6 / 9	6 / 9		
Drainage water pipe diameter	mm	OD Ø 25mm						
Liquid / Gas side Refrigerant piping	mm	6.35mm(1/4in) / 9.52mm(3/8in)	6.35mm(1/4in) / 12.7mm(1/2in)	9.52mm(3/8in) / 15.9mm(5/8in)	9.52mm(3/8in) / 15.9mm(5/8in)	9.52mm(3/8in) / 15.9mm(5/8in)		
Controller		infrared remote control						
Operation temperature		16~30						
Room temperature in Cooling	°C	16~32 / 0~30	16~32 / 0~30	16~32	16~32	16~32		
Room temperature in Heating	°C	-15~50 / -20~24	-15~50 / -20~24	0~30	0~30	0~30		

NOTE: The above design and specifications are subject to change without prior notice for product improvement.

# SMERALDO C

## CASSETTE INDOOR UNIT

MODEL			36T	48	48T	55T
Cooling	Pdesignc	kW	10.5	14.0	14.0	15.3
	SEER	W/W	6.4	6.1	6.1	6.1
	Energy Efficiency Class					
Heating (Average)	Pdesignh	kW	8.2	11.2	11.2	11.8
	SCOP	W/W	4.0	4.0	4.0	4.0
	Energy Efficiency Class					
	Tbiv	°C	-7	-7	-7	-7
Heating (Warmer)	Pdesignh	kW	10.1	11.1	11.1	11.5
	SCOP	W/W	5.1	5.1	5.1	4.9
	Energy Efficiency Class					
	Tbiv	°C			2	
Tol	°C			-15		
Power supply - Indoor	V, Hz, Ph	220-240V, 1Ph, 50Hz				
Power supply - Outdoor	V, Hz, Ph	380-415V, 3Ph, 50Hz	220-240V, 1Ph, 50Hz	380-415V, 3Ph, 50Hz		
Cooling	Capacity	Btu/h	34154 (9200~39000)	40000 (12000~54000)	40000 (12000~54000)	52000 (14000~55000)
	Capacity	kW	10.01 (2.70~11.43)	11.72 (3.52~15.83)	11.72 (3.52~15.83)	15.24 (4.10~16.12)
	Input	W	3044 (890~4150)	3600 (810~5700)	3620 (810~6350)	5700 (1000~6250)
	Current	A	6.5 (1.4~6.5)	15.9 (5.8~27.7)	5.6 (1.8~10.3)	8.8 (2.1~10.7)
	EER	W/W	3.29	3.26	3.24	2.67
Heating	Capacity	Btu/h	38000 (9500~43200)	48000 (14000~58000)	48000 (14000~59000)	62000 (15000~65000)
	Capacity	kW	11.14(2.78~12.66)	14.07 (4.20~17)	14.07 (4.10~17.29)	18.17 (4.40~19.05)
	Input	W	3000 (780~4000)	3750 (910~5800)	3750 (910~5900)	5700 (1020~6350)
	Current	A	5.0 (1.3~6.4)	16.5 (6.6~25.3)	5.7 (1.9~9.6)	8.8 (2.1~10.8)
	COP	W/W	3.71	3.75	3.75	3.19
Indoor air flow (Hi/Mi/Lo)	m³/h	1700/1530/1300	1900/1750/1600	1900/1750/1600	2000/1850/1650	
Indoor sound pressure level (Hi/Mi/Lo/Silent)	dB(A)	51/49/46/39	53/50.5/45/39	51.5/49.0/46.5/38.5	53/50.5/45.5/40	
Indoor sound power level (Hi)	dB(A)	63	66	66	66	
Outdoor sound pressure level (Hi)	dB(A)	63	64	64.0	65	
Outdoor sound power level (Hi)	dB(A)	70	73	73	75	
Dimension (WxDxH) body	mm	830x830x245	830x830x287	830x830x287	830x830x287	
Packing (WxDxH) (body)	mm	910x910x290	910x910x330	910x910x330	910x910x330	
Dimension (WxDxH)(panel)	mm	950x950x55	950x950x55	950x950x55	950x950x55	
Packing (WxDxH) (panel)	mm	1035x1035x90	1035x1035x90	1035x1035x90	1035x1035x90	
Net / Gross weight (body)	kg	27.2 / 31.2	29.3 / 33.5	29.3 / 33.5	29.3 / 33.5	
Net / Gross weight	kg	6 / 9				
Drainage water pipe diameter	mm	OD Ø 25mm				
Liquid / Gas side refrigerant piping	mm	9.52mm (3/8in) / 15.9mm (5/8in)	9.52mm (3/8in) / 15.9mm (5/8in)	9.52mm (3/8in) / 15.9mm (5/8in)	9.52mm (3/8in) / 15.9mm (5/8in)	
Controller		infrared remote control				
Operation temperature		16~30				
Room temperature in Cooling	°C	16~32				
Room temperature in Heating	°C	0-30				

NOTE: The above design and specifications are subject to change without prior notice for product improvement.

# SMERALDO C

## CASSETTE INDOOR UNIT

models 12-18

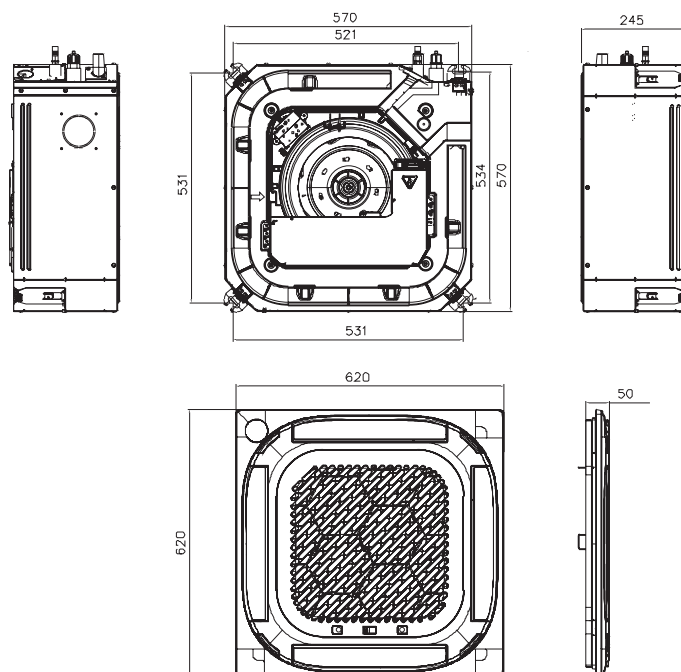

NOTE: The dimensions are expressed in mm

models 24-55T

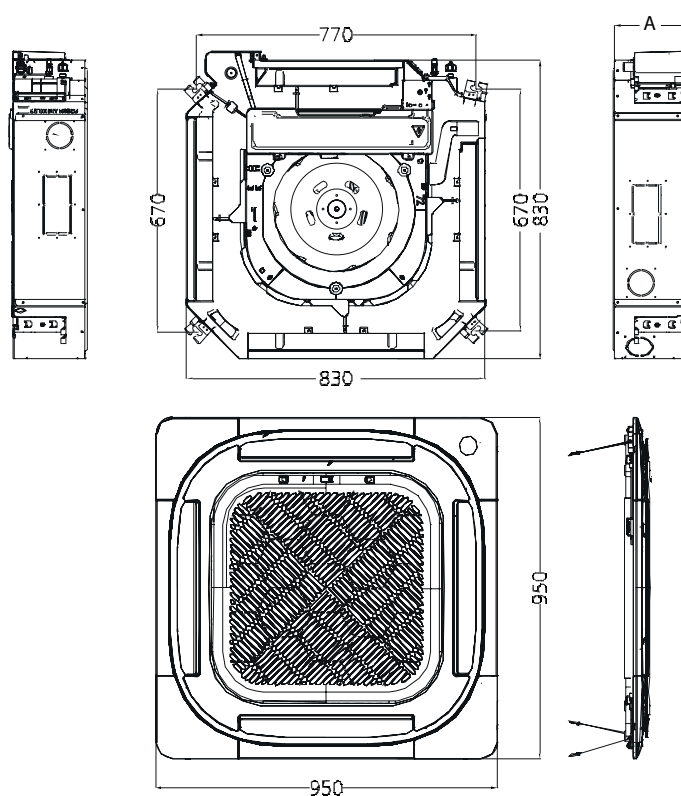

Mod.		A
24	mm	205
36-36T	mm	245
48-48T	mm	287
55T	mm	287

# SMERALDO C

## DUCTED INDOOR UNIT

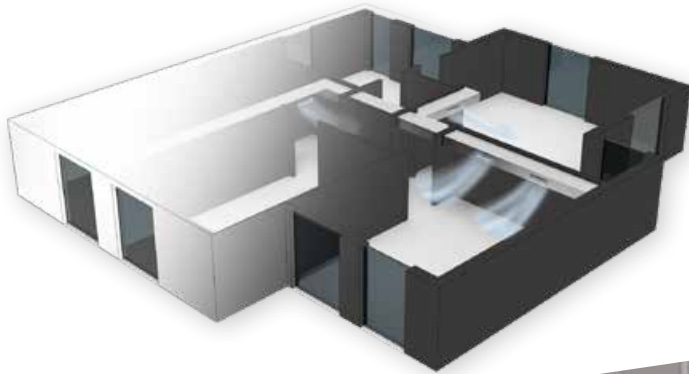

### Perfect solution for room air conditioning using air distribution through a duct network

- Ducted Indoor unit with small dimensions (only 200 mm high for mod. 12, 245 mm high for mod. 18-48, and 300 mm high for mod. 55T). Ideal for installation in false ceilings with low ceiling heights
- Golden Fin protection in coil
- DC Inverter fan: high efficiency and reduced sound level
- Static pressure available up to 160 Pa (depending on model)
- Automatic static pressure adjustment available
- Condensate drainage pump available as an accessory
- Vertical installation possible
- Maximum refrigerant piping lengths: 25-30m for models up to 18, 50m for models 24 and 30, and 75m for models 36-50
- Low noise level
- Possibility of outside air supply
- Flexible installation: air intake direction can be changed from rear side to lower side
- Standard wired remote control with large display for complete control of the unit



R32 GAS	WIFI+APP AVAILABLE	CONDENSATE PUMP	GOLDEN FIN PROTECTION	PRESSURE ADJUSTMENT	STATIC PRESSURE
R32	WIFI+APP				160 Pa 30 Pa

# SMERALDO C















## DUCTED INDOOR UNIT

MODEL			12	18	24	30	36
Cooling	Pdesignc	kW	3.5	5.3	7.1	8.8	10.5
	SEER	W/W	6.5	6.5	6.6	6.6	6.3
	Energy Efficiency Class						
Heating (Average)	Pdesignh	kW	2.7	4.3	5.6	8.0	8.4
	SCOP	W/W	4.1	4.1	4.2	4.2	4.1
	Energy Efficiency Class						
	Tbiv	°C	-7	-7	-7	-7	-7
Heating (Warmer)	Pdesignh	kW	3.4	5.2	6.5	8.2	10
	SCOP	W/W	5.1	5.1	5.4	5.5	5.1
	Energy Efficiency Class						
	Tbiv	°C	2	2	2	2	2
Tol		°C	-15	-15	-15	-15	-15
Power supply - Indoor	V, Hz, Ph	220-240V, 1Ph, 50Hz					
Power supply - Outdoor	V, Hz, Ph	220-240V, 1Ph, 50Hz					
Cooling	Capacity	Btu/h	12000 (1800-13334)	18000 (4500-21000)	24000 (11000-27000)	29400 (7600-34000)	33440 (9400-40000)
	Capacity	kW	3.52 (0.53-3.91)	5.28 (1.32-6.16)	7.03 (3.23-7.92)	8.62 (2.23-9.97)	9.80 (2.75-11.73)
	Input	W	1090 (155-1465)	1590 (360-2130)	2170 (750-2860)	2660 (190-3450)	3030 (900-4300)
	Current	A	4.82 (1.3-6.47)	7.1 (1.6-9.4)	9.6 (4.2-12.6)	11.8 (2.0-15)	13.6 (4.2-19)
	EER	W/W	3.23	3.32	3.24	3.24	3.23
Heating	Capacity	Btu/h	11500 (3400-15241)	20500 (5100-21500)	27200 (9500-29200)	32000 (9200-34100)	35000 (9500-43000)
	Capacity	kW	3.37 (1.00-4.47)	6.01 (1.50-6.31)	8.0 (2.79-8.56)	9.38 (2.70-10)	10.3 (2.78-12.61)
	Input	W	900 (302-1423)	1615 (500-1850)	2000 (640-2500)	2400 (430-2550)	2750 (800-3950)
	Current	A	3.98 (1.48-6.29)	7.2 (2.2-8.1)	9 (3.8-11)	10.6 (3.0-11.5)	12.2 (3.5-17.5)
	COP	W/W	3.74	3.72	3.99	3.91	3.73
Indoor air flow (Hi/Mi/Lo)	m³/h	660/570/470	900/780/650	1200/1000/700	1500/1200/900	1700/1400/1100	
ESP	Rated	Pa	25	25	25	37	37
	Range	Pa	0-100	0-160	0-160	0-160	0-160
Indoor sound pressure level (Hi/Mi/Lo/Silent)	dB(A)	35/33/31/26	36.5/34/31/25	33.5/32.5/31/27.5	39/37/35/30	38/36/33/29	
Indoor sound power level (Hi)	dB(A)	52	53	56	60	62	
Outdoor sound pressure level (Hi)	dB(A)	55.5	59	60	60	65	
Outdoor sound power level (Hi)	dB(A)	62	62	69	70	70	
Dimension (WxDxH) (IU)	mm	700x450x200	700x750x245	1000x750x245	1000x750x245	1200x750x245	
Packing (WxDxH) (IU)	mm	860x540x285	925x850x298	1225x860x304	1225x860x304	1425x860x304	
Net / Gross weight (UI)	kg	16.6 / 19.8	24.4 / 29	31.8 / 37.2	32.7 / 38.3	38.4 / 44.4	
Drainage water pipe diameter	mm	OD Ø 25mm					
Liquid side / Gas side refrigerant piping	mm	6.35mm (1/4in) / 9.52mm (3/8in)	6.35mm (1/4in) / 12.7mm (1/2in)	9.52mm (3/8in) / 15.9mm (5/8in)			
Controller		wired remote control					
Operation temperature	°C	16-30	16-30	16-30	16-30	16-30	
Room temperature in Cooling	°C	16-32	16-32	16-32	16-32	16-32	
Room temperature in Heating	°C	0-30	0-30	0-30	0-30	0-30	

NOTE: The above design and specifications are subject to change without prior notice for product improvement.

# SMERALDO C

## DUCTED INDOOR UNIT

MODEL			36T	42	48	48T	55T	
Cooling	Pdesignc	kW	10.6	12.1	14.0	14.0	15.3	
	SEER	W/W	6.1	6.1	6.1	6.1	6.1	
	Energy Efficiency Class							
Heating (Average)	Pdesignh	kW	8.8	9.5	11.5	11.5	12.5	
	SCOP	W/W	4.0	4.1	4.0	4.0	4.0	
	Energy Efficiency Class							
	Tbiv	°C	-7	-7	-7	-7	-7	
Heating (Warmer)	Pdesignh	kW	10	10.2	11.5	11.2	12.8	
	SCOP	W/W	5.1	5.1	5.1	5.1	5.1	
	Energy Efficiency Class							
	Tbiv	°C	2	2	2	2	2	
Tol	°C	-15	-15	-15	-15	-15		
Power supply - Indoor	V, Hz, Ph	220-240V, 1Ph, 50Hz						
Power supply - Outdoor	V, Hz, Ph	380-415V, 3Ph, 50Hz	220-240V, 1Ph, 50Hz			380-415V, 3Ph, 50Hz		
Cooling	Capacity	Btu/h	31400 (9300-40000)	36300 (10000-42000)	42300 (12000-51000)	42300 (12000-54000)	52000 (14000-59000)	
	Capacity	kW	9.20 (2.726-11.73)	10.64 (2.93-12.31)	12.4 (3.52-14.95)	12.4 (3.52-15.83)	15.24 (4.10-17.29)	
	Input	W	2830 (890-4200)	3290 (680-4500)	3830 (810-6150)	3830 (810-6450)	5250 (1030-6650)	
	Current	A	4.4 (1.4-6.7)	14.6 (3.1-19.8)	16.9 (4-26.7)	6.0 (1.8-10.5)	8.1 (3.1-11.5)	
	EER	W/W	3.25	3.23	3.24	3.24	2.90	
Heating	Capacity	Btu/h	34500 (9500-43800)	46000 (11500-48000)	51600 (14000-59000)	52000 (14000-60000)	60000 (15000-70000)	
	Capacity	kW	10.1 (2.78-12.84)	13.48 (3.37-14.07)	15.12 (4.11-17.30)	15.24 (4.11-17.59)	17.58 (4.40-20.52)	
	Input	W	2710 (780-4000)	3550 (750-4100)	4060 (950-5700)	4100 (950-5800)	4740 (950-6600)	
	Current	A	4.3 (1.3-6.4)	16.0 (3.4-18.5)	17.6 (4.5-25)	7.1 (2-9)	7.4 (2-11.5)	
	COP	W/W	3.75	3.80	3.72	3.72	3.71	
Indoor air flow (Hi/Mi/Lo)	m³/h	1700/1400/1100	2000/1700/1300	2000/1700/1300	2000/1700/1300	2200/1900/1500		
ESP	Rated	Pa	37	50	50	50	50	
	Range	Pa	0-160	0-160	0-160	0-160	0-160	
Indoor sound pressure level (Hi/Mi/Lo/Silent)	dB(A)	39/37/34/29	39/37/35.5/33	46/44/42/36	43.5/41.5/39.5/36	44.5/43/41.5/38		
Indoor sound power level (Hi)	dB(A)	62	62	64	65	66		
Outdoor sound pressure level (Hi)	dB(A)	65	63.5	64.5	64.5	64		
Outdoor sound power level (Hi)	dB(A)	70	72	74	73	75		
Dimension (WxDxH) (IU)	mm	1200x750x245	1200x750x245	1200x750x245	1200x750x245	1200x750x300		
Packing (WxDxH) (IU)	mm	1425x860x304	1425x860x304	1425x860x304	1425x860x304	1425x860x354		
Net / Gross weight (UI)	kg	38.4 / 44.4	40.6 / 46.1	40.4 / 46.8	40.4 / 46.8	42.9 / 49.1		
Drainage water pipe diameter	mm	OD Ø 25mm						
Liquid side / Gas side refrigerant piping	mm	9.52mm (3/8in) / 15.9mm (5/8in)						
Controller		wired remote control						
Operation temperature	°C	16-30	16-30	16-30	16-30	16-30		
Room temperature in Cooling	°C	16-32	16-32	16-32	16-32	16-32		
Room temperature in Heating	°C	0-30	0-30	0-30	0-30	0-30		

NOTE: The above design and specifications are subject to change without prior notice for product improvement.

# SMERALDO C

## DUCTED INDOOR UNIT

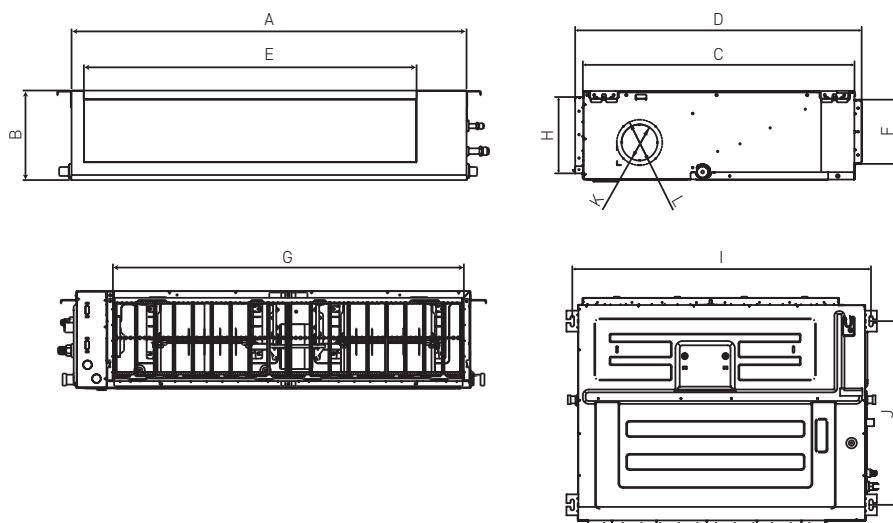

MODEL		Outline dimensions				Air outlet opening size		Air return opening size		Size of mounted lug		Fresh air intake opening size	
		A	B	C	D	E	F	G	H	I	J	K	L
9-12	mm	700	200	450	506	537	152	599	186	741	360	-	-
18	mm	700	245	750	795	527	178	592	212	740	640	100	126
24-30	mm	1000	245	750	795	827	178	892	212	1040	640	100	126
36-48 / 36T-48T	mm	1200	245	750	795	1027	178	1092	212	1240	640	100	126
55T	mm	1200	300	750	795	1027	233	1092	267	1240	640	125	160

# SMERALDO C

## FLOOR / CEILING INDOOR UNIT



**Perfect solution for room air conditioning using the floor/ ceiling, allowing air distribution from the ceiling or from the floor according to the needs of each room**













- Horizontal ceiling or vertical floor installation possible
- Golden Fin protection in coil
- DC Inverter fan, to obtain high efficiency and reduced sound level
- Compact unit with a thickness of 235 mm only
- Infrared remote control as standard with a large display for complete control of the unit (optional wired remote control)
- WIFI connection available (accessory). Possibility of controlling the unit via App



R32 GAS	WIFI+APP AVAILABLE	COMPACT UNIT	CEILING/ FLOOR INST.
			

# SMERALDO C









## FLOOR / CEILING INDOOR UNIT

MODEL			18	24	36	36T
Cooling	Pdesignc	kW	5.4	7.1	10.5	10.5
	SEER	W/W	6.2	6.3	6.4	6.2
	Energy Efficiency Class					
Heating (Average)	Pdesignh	kW	4.0	5.9	8.6	8.6
	SCOP	W/W	4.0	4.1	4.1	4.0
	Energy Efficiency Class					
	Tbiv	°C	-7	-7	-7	-7
Heating (Warmer)	Pdesignh	kW	5.1	5.7	10.0	10.2
	SCOP	W/W	5.1	5.4	5.1	5.1
	Energy Efficiency Class					
	Tbiv	°C	2	2	2	2
Tol		°C	-15	-15	-15	-15
Power supply - Indoor	V, Hz, Ph	220-240V, 1Ph, 50Hz				
Power supply - Outdoor	V, Hz, Ph	220-240V, 1Ph, 50Hz			380-415V, 3Ph, 50Hz	
Cooling	Capacity	Btu/h	18000 (9250-20000)	23200 (10990-27100)	34460 (9300-39000)	34460 (9300-40200)
	Capacity	kW	5.28 (2.71-5.86)	6.80 (3.22-7.95)	10.1 (2.73-11.43)	10.1 (2.73-11.78)
	Input	W	1450 (670-2027)	2060 (750-2730)	3080 (900-4250)	3100 (890-4300)
	Current	A	6.0 (3.2-9)	9.04 (3.9-12.1)	13.6 (4.2-19.0)	6.30 (1.4-6.80)
	EER	W/W	3.64	3.30	3.28	3.26
Heating	Capacity	Btu/h	19000 (8250-21500)	26000 (9280-29000)	40000 (9600-43600)	39960 (9500-43600)
	Capacity	kW	5.57 (2.42-6.30)	7.62 (2.72-8.50)	11.72 (2.78-12.78)	11.71 (2.81-12.78)
	Input	W	1500 (540-1640)	1980 (650-2940)	3160 (800-3950)	3140 (780-3950)
	Current	A	6.6 (2.7-7.3)	8.7 (3.5-10.60)	15.0 (3.5-17.5)	5.5 (1.3-6.20)
	COP	W/W	3.71	3.85	3.71	3.73
Indoor air flow (Hi/Mi/Lo)	m³/h	958/839/723		1192/1023/853	1955/1728/1504	1955/1728/1504
Indoor sound pressure level (Hi/Mi/Lo/Silent)	dB(A)	44/41/37/24		49.5/45.5/36.5/22.5	51.5/48/45/39	51/47.5/45/37
Indoor sound power level (Hi)	dB(A)	57		63	64	64
Outdoor sound pressure level (Hi)	dB(A)	59		60.5	63	63
Outdoor sound power level (Hi)	dB(A)	65		69	70	68
Dimension (WxDxH)	mm	1068x675x235		1068x675x235	1650x675x235	1650x675x235
Packing (WxDxH)	mm	1145x755x318		1145x755x318	1725x755x318	1725x755x318
Net / Gross weight	kg	28/33.3		28/33.1	41.5/48	41.5/48
Drainage water pipe diameter	mm	OD Ø 25mm				
Liquid side / Gas side refrigerant piping	mm	6.35mm (1/4in) / 12.7mm (1/2in)		9.52mm (3/8in) / 15.9mm (5/8in)		
Controller		infrared remote control				
Operation temperature	°C	16-30				
Room temperature in Cooling	°C	16-32				
Room temperature in Heating	°C	0-30				

NOTE: The above design and specifications are subject to change without prior notice for product improvement.

# SMERALDO C

## FLOOR / CEILING INDOOR UNIT

MODEL			48	48T	55T
Cooling	Pdesignc	kW	14.0	14.0	15.3
	SEER	W/W	6.1	6.1	6.1
	Energy Efficiency Class				
Heating (Average)	Pdesigngh	kW	11.2	11.2	11.8
	SCOP	W/W	4.0	4.0	4.0
	Energy Efficiency Class				
	Tbiv	°C	-7	-7	-7
Heating (Warmer)	Pdesigngh	kW	11.5	11.5	11.5
	SCOP	W/W	5.1	5.1	5.1
	Energy Efficiency Class				
	Tbiv	°C	2	2	2
Tol	°C	-15	-15	-15	
Power supply - Indoor	V, Hz, Ph	220-240V, 1Ph, 50Hz			
Power supply - Outdoor	V, Hz, Ph	220-240V, 1Ph, 50Hz	380-415V, 3Ph, 50Hz		
Cooling	Capacity	Btu/h	41600 (12000-54000)	41300 (12000-52000)	52000 (14000-55000)
	Capacity	kW	12.2 (3.52-15.83)	12.1 (3.52-15.24)	15.24 (4.10-16.12)
	Input	W	3770 (810-6350)	3730 (910-6200)	5900 (1100-6500)
	Current	A	16.5 (5.8-27.8)	5.7 (2.1-9.6)	8.9 (3.1-10.8)
	EER	W/W	3.23	3.25	2.58
Heating	Capacity	Btu/h	44000 (14000-59000)	44000 (14000-60000)	62000 (15000-66000)
	Capacity	kW	12.9 (4.10-17.30)	12.9 (4.10-17.59)	18.17 (4.40-19.35)
	Input	W	3470 (910-6050)	3470 (950-5950)	5950 (1120-6350)
	Current	A	15.3 (6.6-26.5)	5.3 (2.2-9.2)	9.1 (3.1-10.5)
	COP	W/W	3.72	3.72	3.05
Indoor air flow (Hi/Mi/Lo)	m³/h	2100/1850/1600	2100/1850/1600	2200/1950/1650	
Indoor sound pressure level (Hi/Mi/Lo/Silent)	dB(A)	53/49/42.5/36	51/49/43/35	53/50/42/36	
Indoor sound power level (Hi)	dB(A)	67	68	70	
Outdoor sound pressure level (Hi)	dB(A)	64	64	65	
Outdoor sound power level (Hi)	dB(A)	74	73	75	
Dimension (WxDxH)	mm	1650x675x235	1650x675x235	1650x675x235	
Packing (WxDxH)	mm	1725x755x318	1725x755x318	1725x755x318	
Net / Gross weight	kg	41.7/48.5	41.7/48.5	42.3/49.2	
Drainage water pipe diameter	mm	OD Ø 25mm			
Liquid side / Gas side refrigerant piping	mm	9.52mm (3/8in) / 15.9mm (5/8in)			
Controller		infrared remote control			
Operation temperature	°C	16-30			
Room temperature in Cooling	°C	16-32			
Room temperature in Heating	°C	0-30			

NOTE: The above design and specifications are subject to change without prior notice for product improvement.

# SMERALDO C

## FLOOR / CEILING INDOOR UNIT

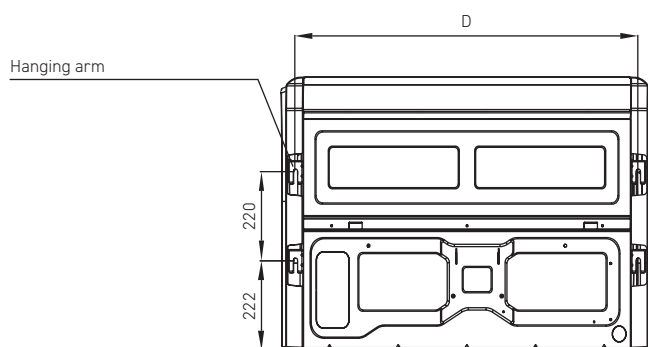
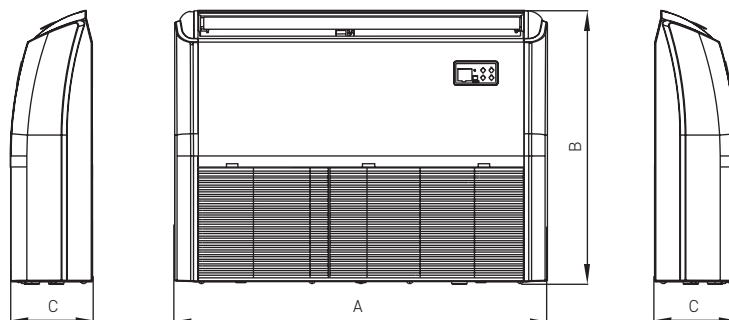
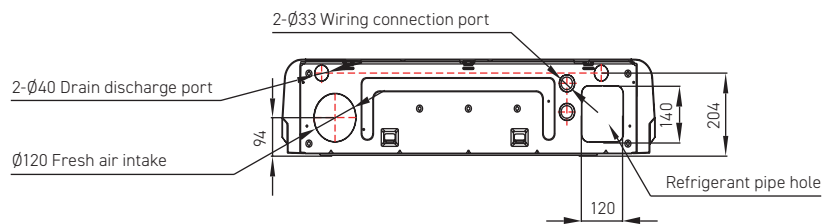

MODEL		A	B	C	D
18-24	mm	1068	675	235	983
36-36T-48-48T-55T	mm	1650	675	235	1565

# SMERALDO C

## Electrical connections / Refrigerant connection lines

MODEL		12	18	24	30	36	36T	42	48	48T	55T	
Outdoor unit power	Phase	1-phase					3-phase		1-phase		3-phase	
	Frequency and voltage	220-240V, 50Hz					380-415V, 50Hz		220-240V, 50Hz		380-415V, 50Hz	
	Power wiring	mm <sup>2</sup>	3×1.5		3×2.5		3×4.0		5×2.5		3×4.0 3×6.0 5×2.5	
	Circuit breaker / Fuse	A	25 / 20		40 / 30		25 / 20		50 / 40		32 / 25	
Indoor / Outdoor connecting wiring	Strong electric signal	mm <sup>2</sup>	4×1.0									

Refrigeration connections within the limits indicated below are allowed for the units:

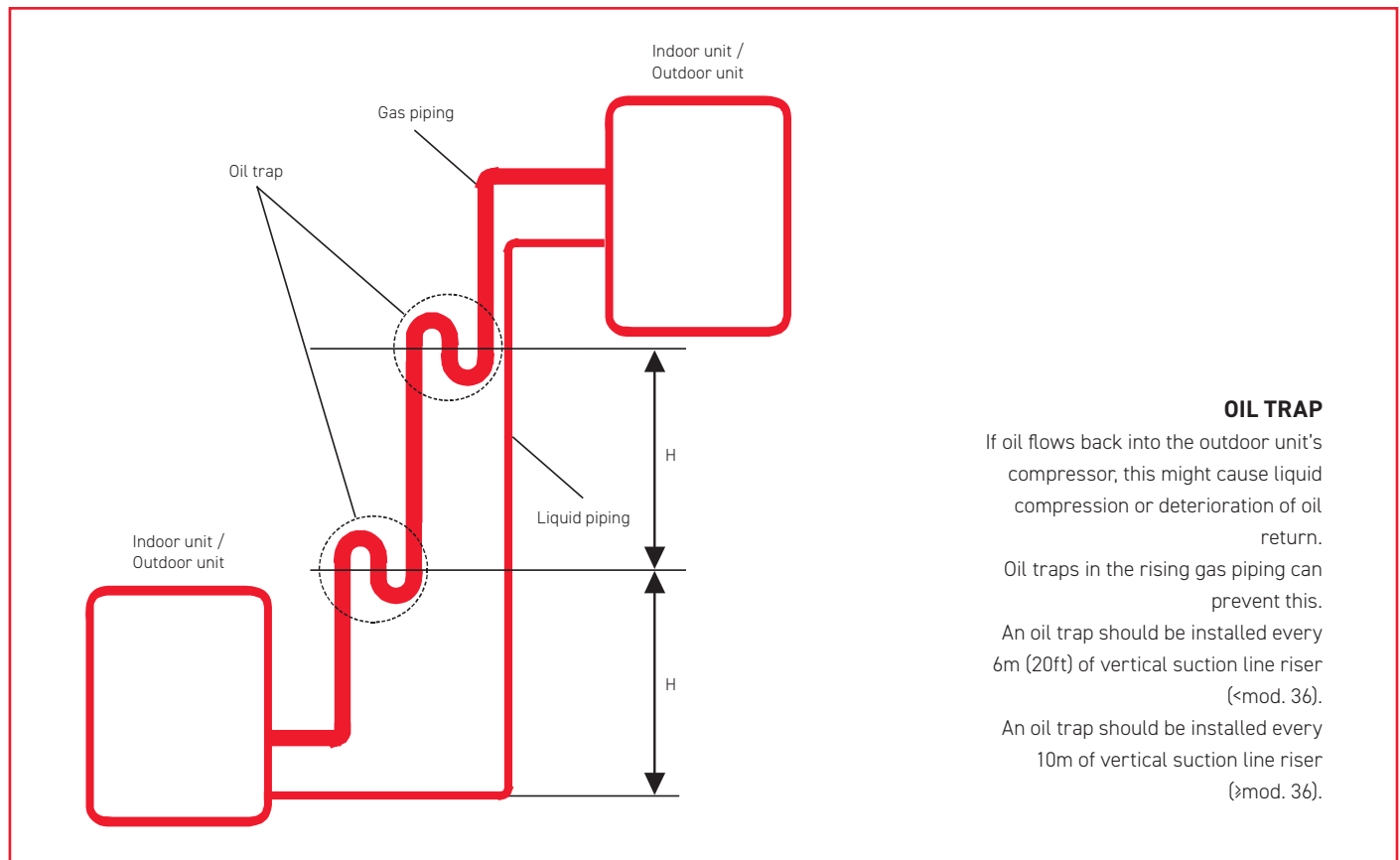

MOD.		12	18	24	30	36	36T	42	48	48T	55T	
Diameter	Liquid connection	-	6.35mm (1/4in)			9.52mm (3/8in)						
	Gas connection	-	9.52mm (3/8in)	12.7mm (1/2in)	15.9mm (5/8in)							
Maximum pipe length	m	25	30	50				75				
Max height difference	m	10	20	25				30				
Maximum pipe length with standard refrigerant charge	m	5						10				
Oil trap (H)	m	6						10				
Refrigerant	Type	R32										
	Charge	kg	0.71	1.15	1.4	1.8	2.4	2.4	2.8	2.9	2.9	3.2
Additional charge	g/m	12						24				

Example: if the length of liquid pipe is more than 5 meters, for instance 20 meters the additional refrigerant charge is calculated as:  
 for models 12=18 Additional charge = (20-5) x 12 = 180 g / for models 24=55 Additional charge = (20-5) x 24 = 360 g







The illustrations and data provided are indicative. Lamborghini CaloreClima reserves the right to make any changes deemed to be most appropriate for the improvement of the product or of the service offered without being obliged to give prior notice.

The images in this catalogue are under copyright owned by Lamborghini CaloreClima.