



Lamborghini
CALORECLIMA



Dora Tech

Air-water heat pump
for domestic hot water production



DORA TECH

INTRODUCTION









DORA TECH is a brand new range of storage heat pump water heaters for the production of domestic hot water, suitable for small residential applications.

It is a smart solution for heating domestic water, which uses electricity, air and possibly solar thermal and photovoltaic energy, without any use of traditional fuels. Efficiency, ecology, flexibility and the new aesthetics are the characteristics that distinguish DORA TECH and diversify it compared to a traditional electric water heater.

* The 90 and 120 LT models use R-290 gas, a valid "green" alternative to the more common refrigerants with high GWP (Global Warming Potential). This is a naturally occurring hydrocarbon (HC) with a GWP of 3 and an ODP (Ozone Depletion Potential) of 0.



THE RANGE			Capacity	Heat output	Absorbed electric power	Solar thermal integration	Gas type	ERP class	Load profile	No. persons
			L	W	W					
LT	Wall Operation (-5/43°C)	90	89	833	270	NO	R290*	A	M	2
		120	118	833	270	NO	R290*	A	M	2
LT	Floor-standing Operation (-7/38°C)	200	192	1820	430	NO	R134A	A	L	3
		260	250	1820	430	NO	R134A	A	XL	4
LT-S	Floor-standing Operation (-7/38°C)	200	187	1820	430	YES	R134A	A	L	3
		260	247	1820	430	YES	R134A	A	XL	4
HT	Floor-standing Operation (4/43°C)	200	187	1600	370	NO	R134A	A	L	3
		260	247	1600	370	NO	R134A	A	XL	4

DORA TECH										
		Energy monitoring	Installation in cascade	Optimization from photovoltaic	Integrated solar thermal control	Wi-Fi remote control	Anti legionella sanitization	Scheduling	Smart grid	Active defrost
LT Wall	90	•	-	•	-	•	•	•	•	•
	120	•	-	•	-	•	•	•	•	•
LT Floor-standing	200	•	•	•	-	•	•	•	•	•
	260	•	•	•	-	•	•	•	•	•
LT-S Floor-standing	200	•	•	•	•	•	•	•	•	•
	260	•	•	•	•	•	•	•	•	•
HT Floor-standing	200	•	•	•	-	•	•	•	•	-
	260	•	•	•	-	•	•	•	•	-

INCENTIVES...

WHEN SAVING IS A MUST

DORA TECH exploits all the characteristics and technology of air-water heat pumps for the production of **domestic hot water**.
Only 25% of the system's energy requirement comes from electricity

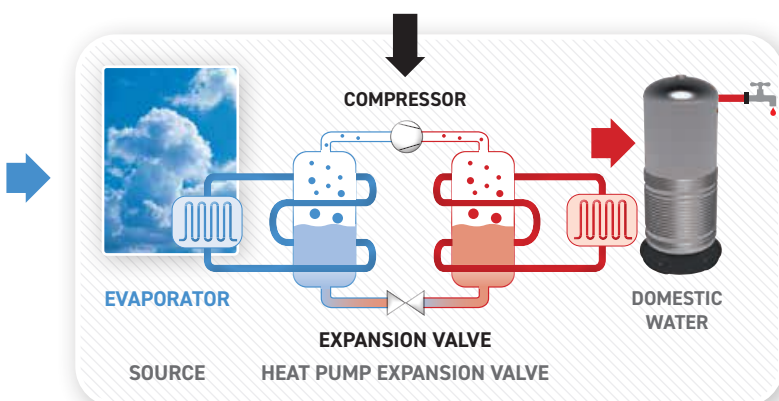

ELECTRONICS...

EASIER THAN THAT!

The **DORA TECH** user interface features a very simple and intuitive display

- > **White** backlit LEDs for managing the temperature, functions and energy monitoring
- > **Red** backlit LEDs for alarm warnings
- > The 4 side touch buttons allow DORA Tech to be switched on/off (⏻); navigating the MENU (**SET**) and increase (+) or decrease (-) the setting values
- > Energy monitoring via display or App



OPERATING MODES

To satisfy the widest range of needs, **DORA TECH** offers **5** different operating modes:

RENEWABLE ENERGY ONLY		
ECO MODE	HP	DORA TECH works ONLY in heat pump mode. The supplementary heater switches on as support only if the external temperature is outside the working range (Tmax 62°C)
PREFERRED USE OF RENEWABLE ENERGY		
AUTO MODE	HP +	DORA TECH favors heat pump operation. The supplementary heater switches on as support only if the tank temperature increases too slowly (>4°C/30 min) or if the external temperature is outside the working range (Tmax 62°C)
COMBINED USE OF RENEWABLE ENERGY AND ELECTRICITY		
BOOST MODE	 FLASHING	DORA TECH works simultaneously in heat pump mode and with the supplementary heater. Setpoint adjustable to 75°C
USE OF ELECTRICITY ONLY		
ELECTRIC MODE		DORA TECH works only with the supplementary heater. Setpoint adjustable to 75°C
AIR RECIRCULATION ONLY		
FAN MODE	FAN	DORA TECH works exclusively in ventilation mode (HT model only). Heat pump and supplementary heater are OFF

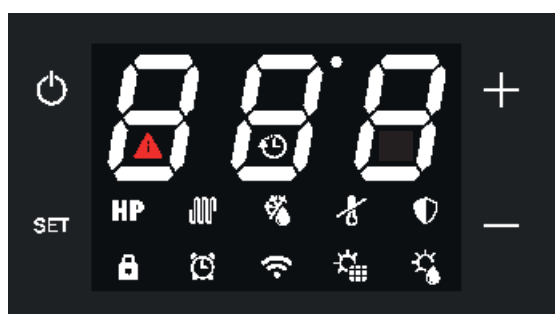

- | | | | |
|--|------------------------|--|---------------------------|
| | ALARM | | BUTTON LOCK |
| | HEAT PUMP | | SCHEDULING |
| | HEATING ELEMENT ACTIVE | | WI FI |
| | DEFROST | | PHOTOVOLTAIC |
| | ANTIFREEZING | | SOLAR THERMAL / HOT WATER |
| | ANTI LEGIONELLA | | SMART GRID |

INTEGRATION...

DORA TECH GETS ALONG WITH EVERYONE

All **DORA TECH** versions provide for the possibility of using renewable energy supplied by a **photovoltaic system** (electricity) or from a **solar thermal system** (thermal energy).

This last solution is possible ONLY for models **200 LT-S** and **260 LT-S**, whose tank houses a coil used as a solar exchanger.

SOLAR SYSTEM CONNECTION METHOD

DORA TECH manages all the components of the Solar Circuit directly with its **own** electronics, optimizing heat pump operation according to the availability of Solar Energy.

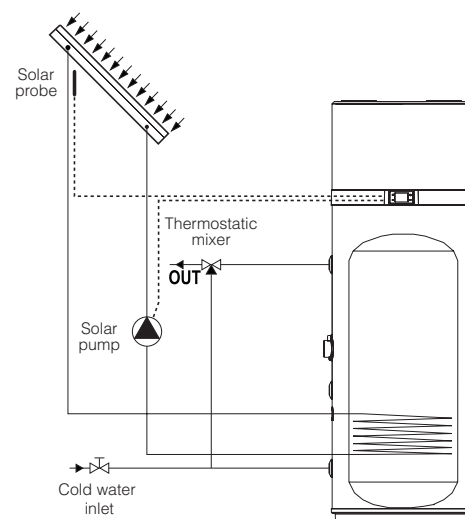

PHOTOVOLTAIC SYSTEM

DORA TECH is able to manage the surplus Electricity supplied by a Photovoltaic System through signaling of the Inverter via a voltage-free contact.

In this mode, **DORA TECH** will prepare the domestic hot water at a higher temperature Set Point (settable) than the ECO/AUTO modes, for exploiting the free energy available.

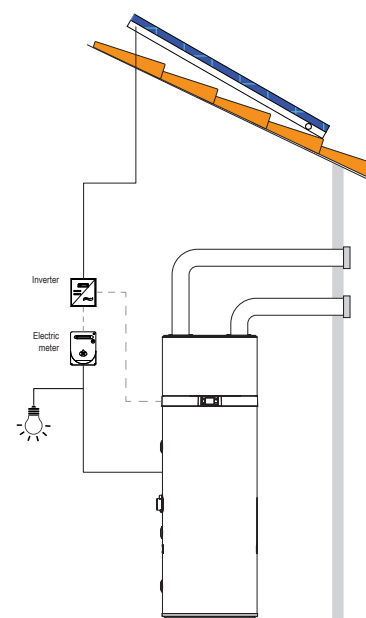

BUT FOR THOSE WHO WANT MORE WI-FI AND APP

DORA TECH heat pump water heaters come **as standard with a WiFi module** integrated in the product in order to be connected to the home WiFi network (WiFi router) and therefore controlled via APP.

By downloading the dedicated **LAMBORGHINI CALORECLIMA HOME** App for free, DORA Tech can be fully managed at any time.

After quick and easy registration it will be possible to remotely manage the comfort of hot water in the home.



**LAMBORGHINI
CALORECLIMA
HOME**

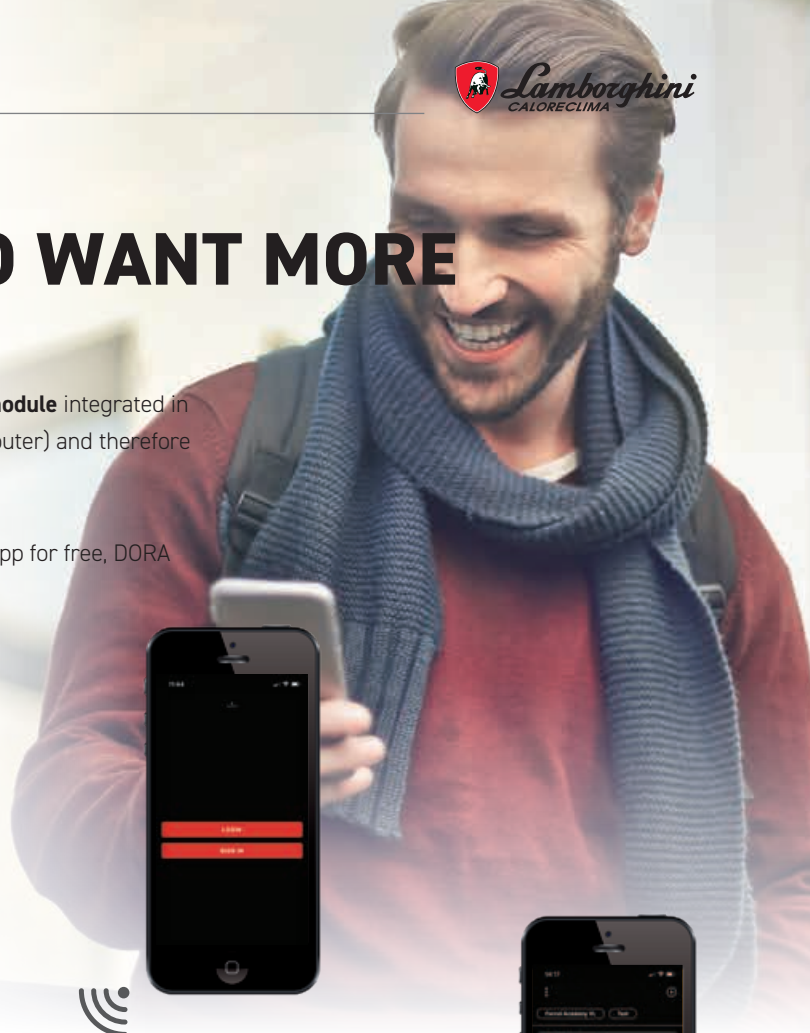

After downloading the app and logging in, you will be able to view and manage all your Lamborghini CaloreClima heat pumps and hybrid systems

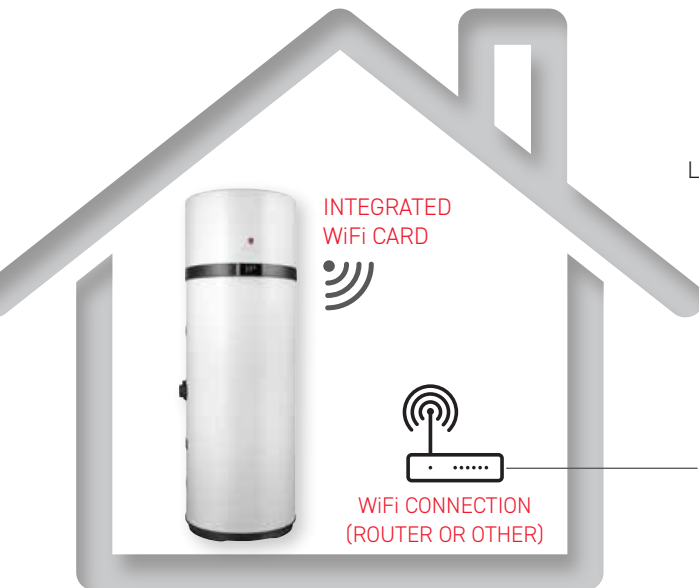

With **LAMBORGHINI CALORECLIMA HOME** it is possible to modify the operating parameters, and program switching off and on. It is a very intuitive and easy to use App. Here are some examples:

SCHEDULING

ENERGY MONITORING



INSTALLATIONS

TYPES OF INSTALLATION

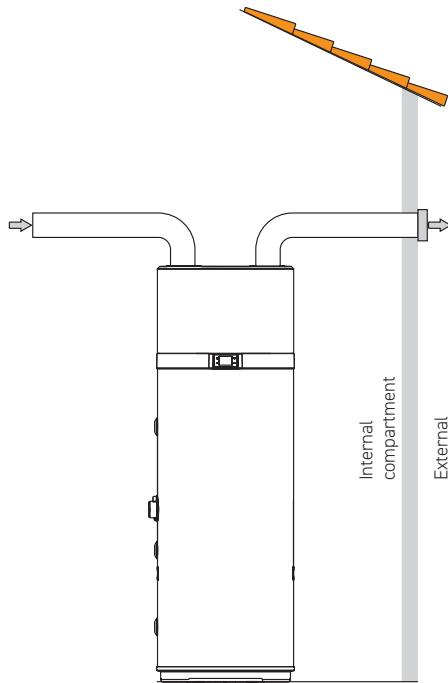

Fig. 1
Example of air discharge connection (this type of installation can only be made with models 200 and 260)

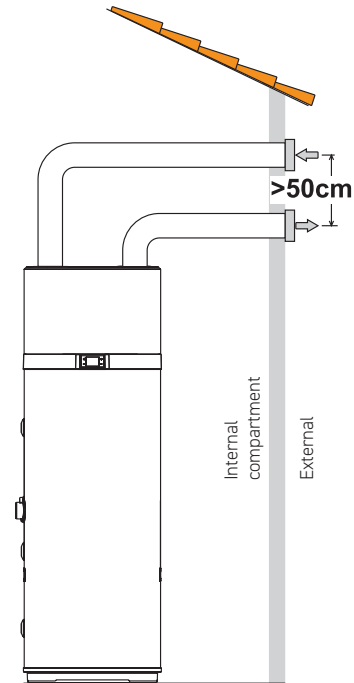

Fig. 2
Example of air discharge connection (this type of installation can only be made with models 200 and 260)



The heat pump requires adequate air ventilation. A possible dedicated air duct is shown in Fig. 1. It is also important to ensure adequate ventilation of the room containing the unit. An alternative solution is shown in the figure below (Fig. 2): it provides for a second ducting that draws air from the outside instead of directly from the inside room.

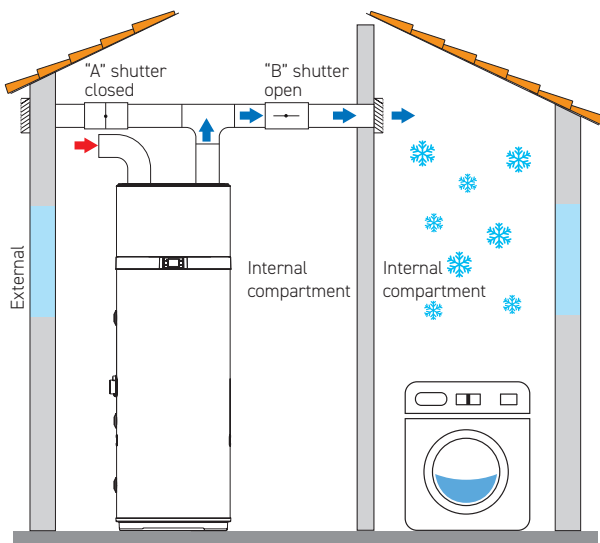

Fig. 3
Example of installation in the summer period (this type of installation can only be done with models 200 and 260).

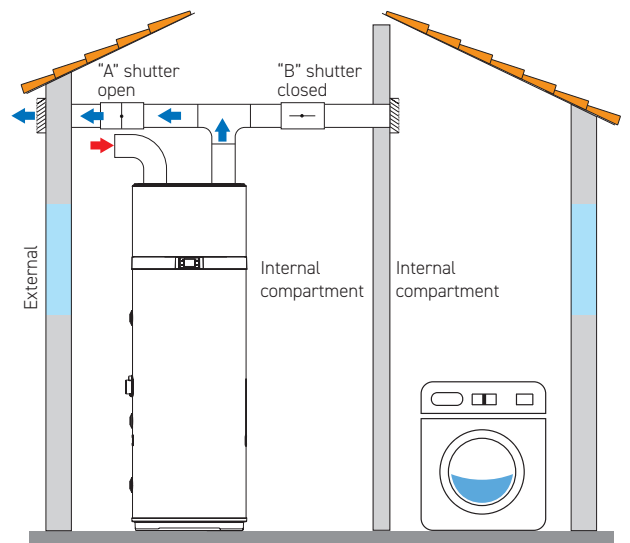

Fig. 4
Example of installation in the winter period (this type of installation can only be done with models 200 and 260).

One of the peculiarities of heat pump heating systems is that these units produce a considerable lowering of the air temperature, generally expelled to the outside of the home. As well as being colder than the ambient air, the expelled air is also completely dehumidified, therefore the air flow can be returned inside for the summer cooling of specific rooms or areas. Installation provides for splitting of the extraction pipe, which is fitted with two dampers ("A" and "B") for directing the air flow to the outside (fig. 3) or the inside of the home (fig. 4).

INSTALLATION - COMPONENTS

INSTALLATION IN CASCADE

To best satisfy users requiring lots of domestic hot water, we have designed the electronic control system so that **a cascade of up to 8 floor standing DORA TECH units can be created and managed**. The DORA TECH array does not need any external regulator and is able to **self-configure** itself with "master/slave" logic to manage any dynamic linked to cascade operation. The array parameters can be read or modified from the MASTER display or remotely via the Lamborghini CaloreClima HOME App. The various features of the DORA TECH cascade system include:

- Management of operating cycles with rotation of rotation sequences
- Smart draw-off of DHW from the highest potential water heater
- Continuity of service in case of an array water heater failure

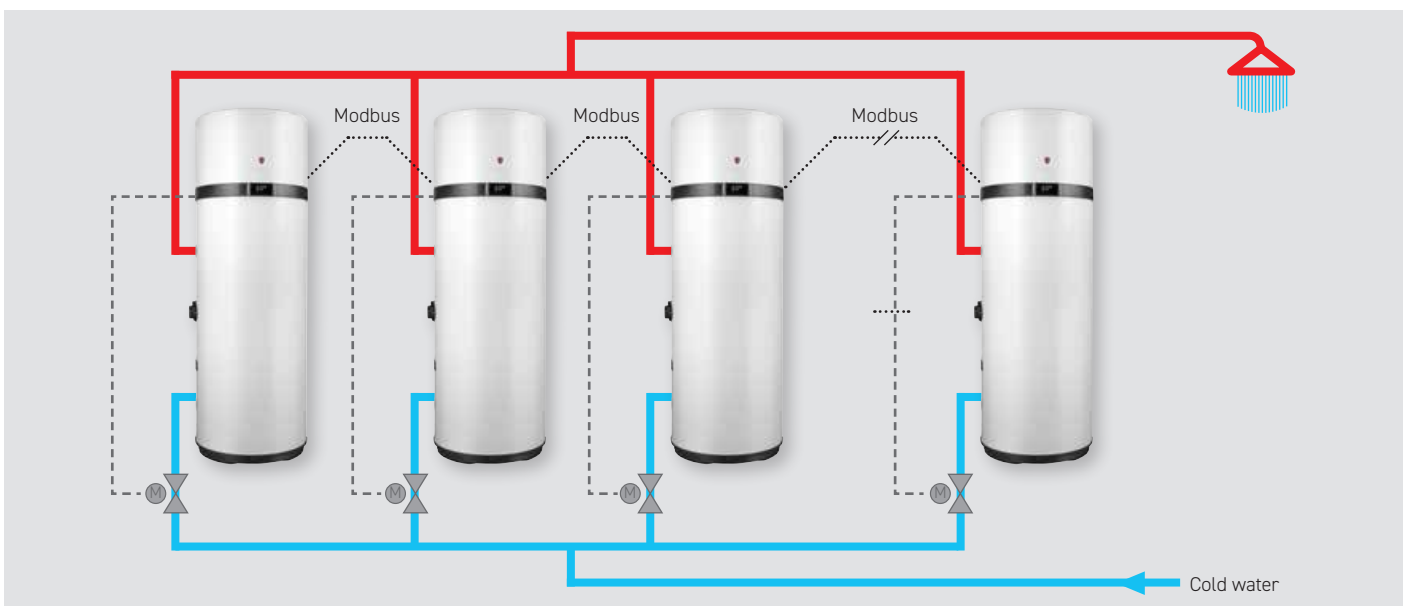

DORA TECH IN PILLS



Photovoltaic optimization

When the symbol on the display is lit up, the energy produced by the photovoltaic system is used to heat the water inside the tank



Scheduling

For setting the activation and/or deactivation time bands



Wi-Fi remote control

Light on when the connection status between the unit and an external Wi-Fi router is satisfied



Smart grid

When this symbol is lit up on the display, the unit works during the reduced rate time band



Integrated solar thermal control

When the symbol is lit up, solar energy is used to heat the tank water (models LT-S)



Anti-legionella sanitization

A heating/sanitization cycle of the water inside the tank is done by means of an electrical heating element



Active defrost

When the unit detects a defrost temperature $\leq 1^{\circ}\text{C}$, all the procedures are activated to restore optimal operating conditions



SET button

For selecting the various functions/operating modes, selecting parameters and confirming the modified value



Heat pump operation

With this mode only the heat pump is used within the product operating limits



Operation with heating element

With this mode only the electrical heating element is used



Active button lock

In any status, the button lock function is activated 60 seconds after the last press



Frost protection

The frost protection function is activated when the water temperature is below/equal to 5°C . It switches on the heating element until 12°C is reached



ON/OFF button

For switching the unit on and off, putting it in standby, locking the buttons and saving the modified parameters



Alarm

It signals a unit fault or "protection active" status



Energy monitoring

"Energy monitoring" function available via display or via the App



Operation in cascade

It is possible to create/manage a cascade of up to 8 DORATech units without any external regulator and is self-configurable

COMPONENTS

WALL VERSION CONNECTIONS (90 - 120 LT)



FLOOR-STANDING VERSION CONNECTIONS (200 - 260 LT)

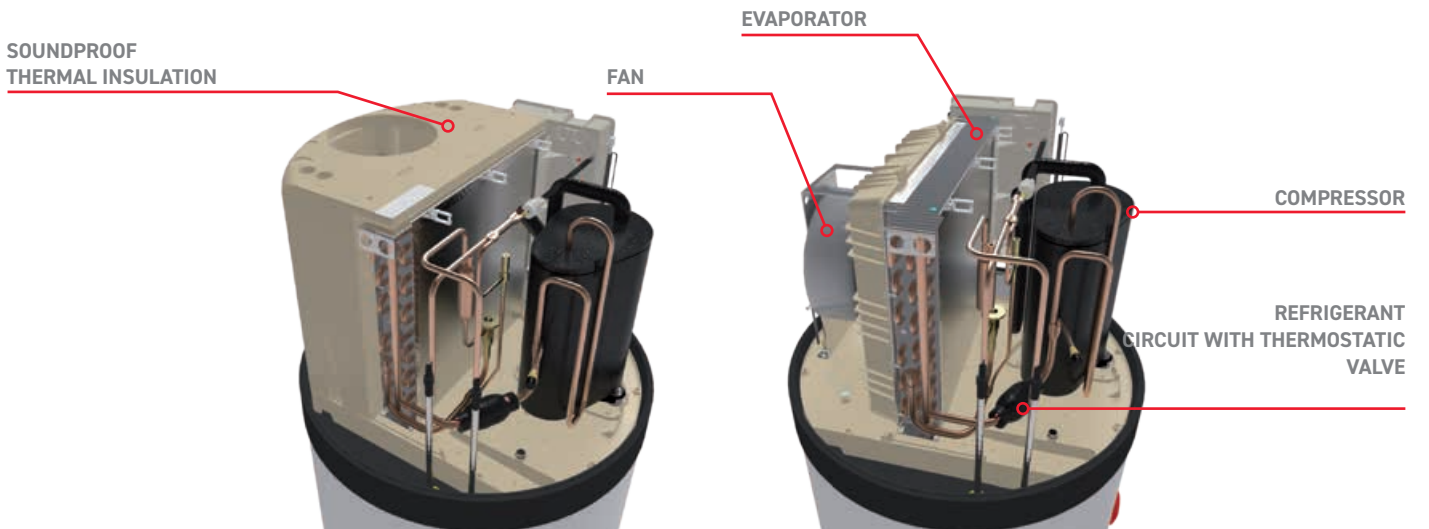
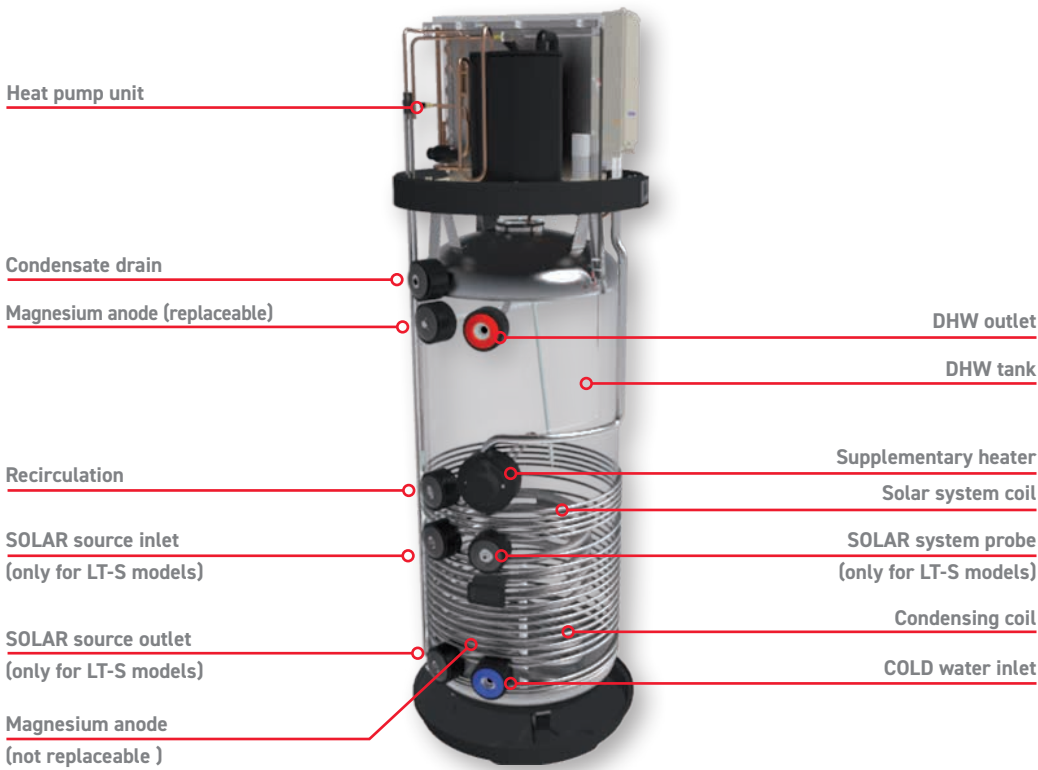

DIMENSIONS

TECHNICAL DRAWINGS

MODEL
90-120 liters

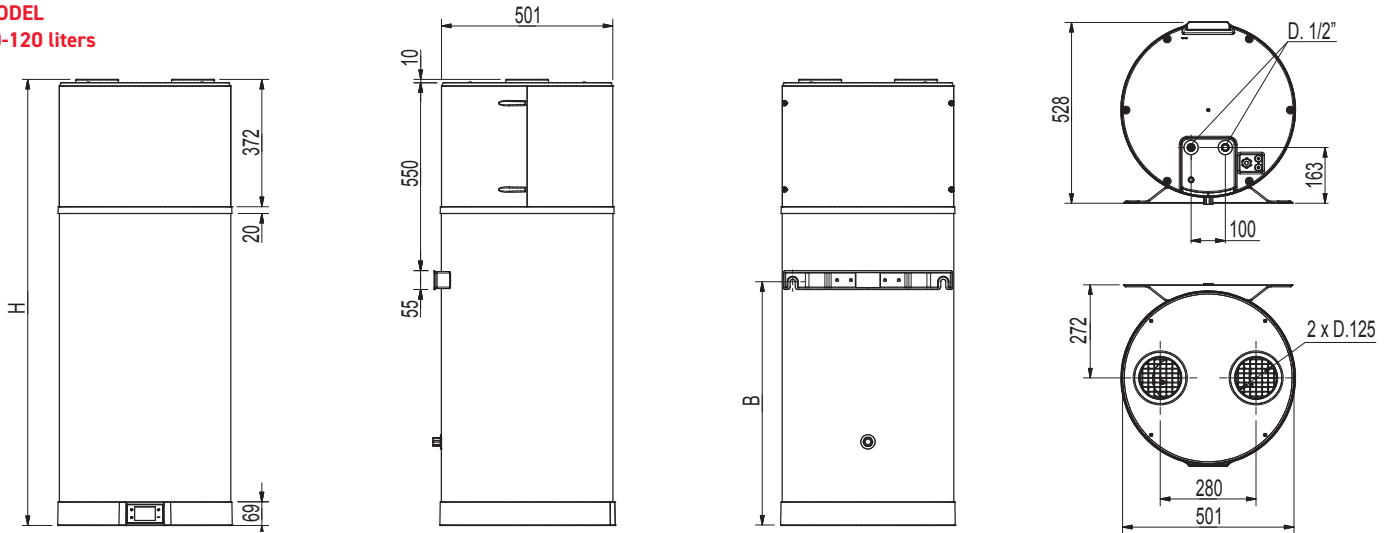

MODEL
200-260 liters

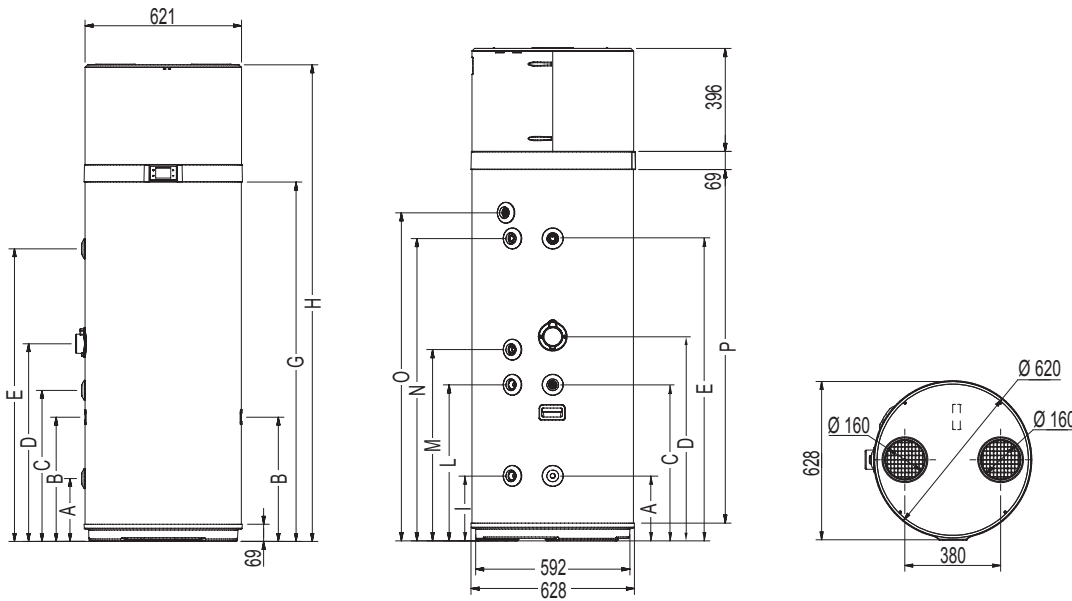

CONNECTIONS

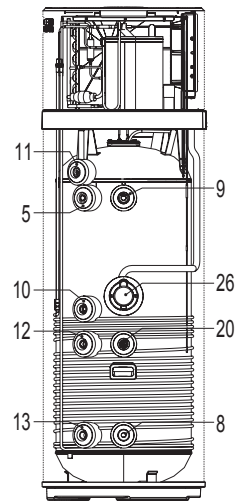

MOD.	ø	LT		LT		LT-S		HT		
		90	120	200	260	200	260	200	260	
A	mm	1"G	-	-	250	250	250	250	250	250
B	mm	-	711	963	-	-	490	493	-	-
C	mm	1/2"G	-	-	600	600	600	600	600	600
D	mm	-	-	-	705	785	705	785	705	785
E	mm	1"G	-	-	876,5	1162	876,5	1162	876,5	1162
G	mm	-	-	-	1142	1427	1142	1427	1142	1427
H	mm	-	1303	1555	1607	1892	1607	1892	1607	1892
I	mm	3/4"G	-	-	-	-	250	250	-	-
L	mm	3/4"G	-	-	-	-	599	600	-	-
M	mm	3/4"G	-	-	705	735	705	735	705	735
N	mm	3/4"G	-	-	877	1162	877	1162	877	1162
O*	mm	1/2"G	-	-	976	1261	976	1261	976	1261
P	mm	-	-	-	1073	1358	1073	1358	1073	1358

LEGEND

- 8** Cold water inlet connection
- 9** Hot water outlet connection
- 10** Recirculation arrangement
- 11** Condensate drain
- 12** Inlet thermal coil arrangement (only for **LT-S** models)
- 13** Arrangement for outlet thermal coil (only for **LT-S** models)
- 20** Solar probe holder well (only for **LT-S** models)
- 23** Tube for safety thermostat bulb
- 26** Compartment for accessing heating element and safety thermostat bulb

* Outlet connection in plastic material

EXAMPLE DIAGRAMS OF NEW SYSTEMS

DORA TECH, IDOLA S HYBRID C, PHOTOVOLTAIC

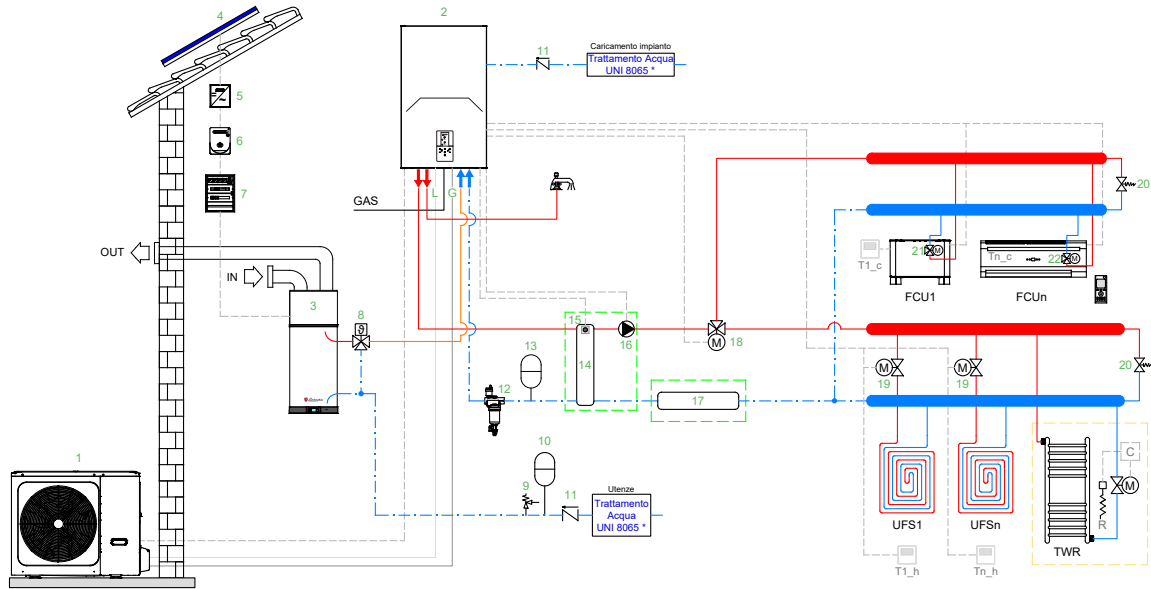

LEGEND 1 Outdoor unit 2 Indoor unit 3 Heat pump water heater 4 Photovoltaic panel 5 Inverter 6 Counter 7 Electrical panel 8 Thermostatic mixing valve 9 DHW safety valve 10 DHW expansion vessel 11 Non-return valve 12 Dirt separator 13 Expansion vessel 14 Parallel inertial storage, hydraulic separation 15 Inertial storage top probe Tbt1 16 Circulating pump P_o 17 Inertial storage in series 18 Two-way diverter valve SV2 19 Motorized zone valve 20 Bypass valve 21 Three-way valve (accessory, to be installed inside the fan coil) 22 Integrated three-way valve T1...n_c Cooling request room thermostat T1...n_h Heating request room thermostat FCU1...n Cooling only air terminal FHL1...n Radiant floor/radiator heating only in n zones TWR Towel warmer for bathroom integration: if connected to the heating system it must be integrated with heating element (R) activated by the command (C) which simultaneously closes the valve (M); if not connected to the system, heating is provided only by the heating element (R) activated by the command (C) G Gas Line L Liquid line * OPTIONAL * See Water treatment diagram according to UNI 8065

DORA TECH, IDOLA S HYBRID C, SOLAR THERMAL, PHOTOVOLTAIC

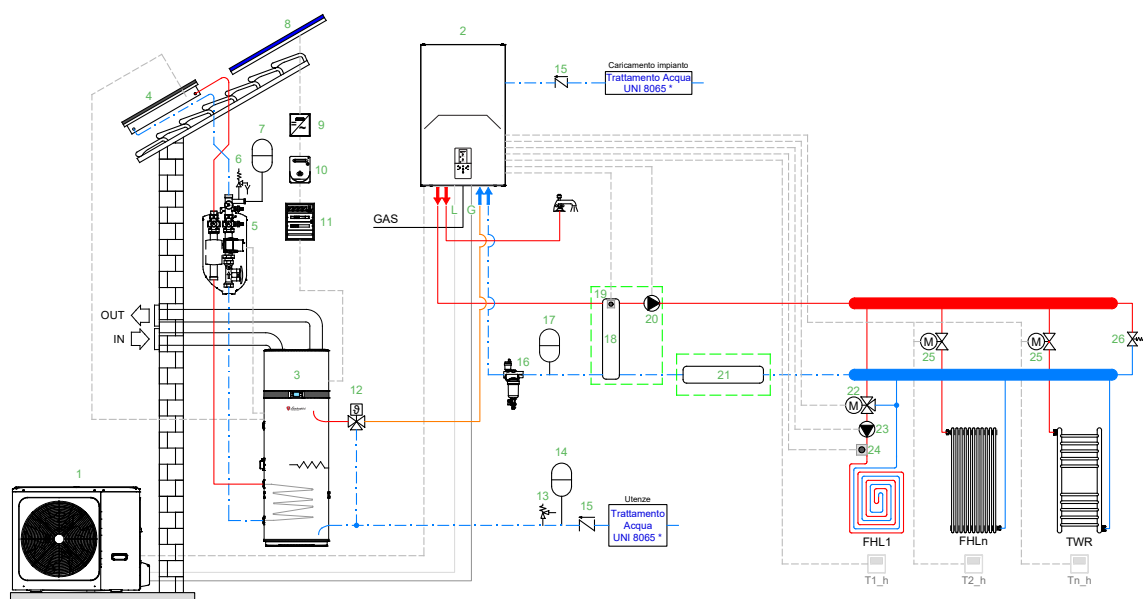











LEGEND 1 Outdoor unit 2 Indoor unit 3 Heat pump water heater 4 Solar collector 5 Solar thermal circulating unit 6 Safety valve 7 Solar thermal circuit expansion vessel 8 Photovoltaic panel 9 Inverter 10 Counter 11 Electrical panel 12 Thermostatic mixing valve 13 DHW safety valve 14 DHW expansion vessel 15 Non-return valve 16 Dirt separator 17 Expansion vessel 18 Parallel inertial storage, hydraulic separation 19 Inertial storage top probe Tbt1 20 Circulating pump P_o 21 Inertial storage in series 22 Three-way mixing valve SV3 23 Mixed zone circulating pump P_c 24 Mixed zone probe TW2 25 Motorized zone valve 26 Bypass valve T1...n_c Cooling request room thermostat T1...n_h Heating request room thermostat FCU1...n Cooling only air terminal FHL1...n Radiant floor/radiator heating only in n zones TWR Towel warmer for bathroom integration G Gas line L Liquid line * OPTIONAL * See Water treatment diagram according to UNI 8065

DORA TECH LT 90-120

PERFORMANCE



							
Energy Monitoring	Installation in cascade	Optimization from Photovoltaic	Wi-Fi Remote Control	Anti Legionella Sanitization	Scheduling	Smart grid	Active defrost

MODEL		90 LT	120 LT
Nominal storage capacity	L	89	118
Max. hot water capacity at 40°C	L	102	145
Storage dispersion	W	40	46
Max. DHW temperature with heat pump only	°C	62	62
Max. DHW temperature with supplementary electric booster	°C	75	75
Integrated heating element power	W	1200	1200
Average absorbed power in heating	W	270	270
Heat output from pump	W	607	613
Dimensions (∅ x H)	mm	510 x 1333	510 x 1555
Empty weight	kg	49	55
Max. water pressure	bar	7	7
Max. air temperature	°C	43	43
Min. air temperature	°C	-5	-5
Nominal air flow	m ³ /h	170	170
Cold air outlet max. available head	Pa	110	110
Duct diameter	mm	125	125
Required room volume	m ³	15	15
Power supply parameters	V-Hz	230V - 50Hz	230V - 50Hz
Protection rating		IP24	IP24
Indoor sound power Lw(A)	dB(A)	54	53
Gas type		R290	R290
Charge quantity	g	150	150
Heating time 7°C in ECO mode	hh:mm	05:52*	08:15*
COP DHW 7°C		3.12	2.75
Internal coil for solar		--	--
Energy efficiency class for heating water in average climatic conditions			
Water heating energy efficiency % in average climatic conditions	%	134	119
Annual energy consumption in average climatic conditions	kW/h	383	430
Declared load profile		M	M

* Test in accordance with EN16147-2017 with air inlet temperature at 7°C (6°C), boiler storage ambient temperature 20°C, water heating from 10°C to 55°C



** Test in accordance with EN16147-2017 with air inlet temperature at 14°C (13°C), boiler storage ambient temperature 20°C, water heating from 10°C to 55°C

DORA TECH LT 200-260

PERFORMANCE



								
Energy Monitoring	Installation in cascade	Optimization from Photovoltaic	Integrated solar thermal control	Wi-Fi Remote Control	Anti Legionella Sanitization	Scheduling	Smart grid	Active defrost

MODEL		200 LT	260 LT
Nominal storage capacity	L	192	250
Max. hot water capacity at 40°C	L	247	340
Storage dispersion	W	60	70
Max. DHW temperature with heat pump only	°C	62	62
Max. DHW temperature with supplementary electric booster	°C	75	75
Integrated heating element power	W	1500	1500
Average absorbed power in heating	W	430	430
Heat output from pump	W	1339	1249
Dimensions (∅ x H)	mm	621 x 1607	621 x 1892
Empty weight	kg	88	100
Max. water pressure	bar	7	7
Max. air temperature	°C	43	43
Min. air temperature	°C	-7	-7
Nominal air flow	m ³ /h	450	450
Cold air outlet max. available head	Pa	117	117
Duct diameter	mm	160	160
Required room volume	m ³	>20	>20
Power supply parameters	V-Hz	230V - 50Hz	230V - 50Hz
Protection rating		IP24	IP24
Indoor sound power Lw(A)	dB(A)	53	51
Gas type		R134a	R134a
Charge quantity	g	1000	1000
Heating time 7°C in ECO mode	hh:mm	06:27*	09:29*
COP DHW 7°C		3.23	3.37
Internal coil for solar		--	--
Energy efficiency class for heating water in average climatic conditions			
Water heating energy efficiency % in average climatic conditions	%	135	138
Annual energy consumption in average climatic conditions	kWh	761	1210
Declared load profile		L	XL

* Test in accordance with EN16147-2017 with air inlet temperature at 7°C (6°C), boiler storage ambient temperature 20°C, water heating from 10°C to 55°C



** Test in accordance with EN16147-2017 with air inlet temperature at 14°C (13°C), boiler storage ambient temperature 20°C, water heating from 10°C to 55°C

DORA TECH LT-S 200-260

PERFORMANCE



								
Energy Monitoring	Installation in cascade	Optimization from Photovoltaic	Integrated solar thermal control	Wi-Fi Remote Control	Anti Legionella Sanitization	Scheduling	Smart grid	Active defrost

MODEL		200 LT-S	260 LT-S
Nominal storage capacity	L	187	247
Max. hot water capacity at 40°C	L	241	335
Storage dispersion	W	60	70
Max. DHW temperature with heat pump only	°C	62	62
Max. DHW temperature with supplementary electric booster	°C	75	75
Integrated heating element power	W	1500	1500
Average absorbed power in heating	W	430	430
Heat output from pump	W	1339	1249
Dimensions (Ø x H)	mm	621 x 1607	621 x 1892
Empty weight	kg	97	109
Max. water pressure	bar	7	7
Max. air temperature	°C	43	43
Min. air temperature	°C	-7	-7
Nominal air flow	m³/h	450	450
Cold air outlet max. available head	Pa	117	117
Duct diameter	mm	160	160
Required room volume	m³	>20	>20
Power supply parameters	V-Hz	230V - 50Hz	230V - 50Hz
Protection rating		IP24	IP24
Indoor sound power Lw(A)	dB(A)	53	51
Gas type		R134a	R134a
Charge quantity	g	1000	1000
Heating time 7°C in ECO mode	hh:mm	06:27*	09:29*
COP DHW 7°C		3.23	3.37
Internal coil for solar		0.72	0.72
Energy efficiency class for heating water in average climatic conditions			
Water heating energy efficiency % in average climatic conditions	%	135	138
Annual energy consumption in average climatic conditions	kW/h	761	1210
Declared load profile		L	XL

* Test in accordance with EN16147-2017 with air inlet temperature at 7°C (6°C), boiler storage ambient temperature 20°C, water heating from 10°C to 55°C



** Test in accordance with EN16147-2017 with air inlet temperature at 14°C (13°C), boiler storage ambient temperature 20°C, water heating from 10°C to 55°C

DORA TECH HT 200-260

PERFORMANCE



								
Energy Monitoring	Installation in cascade	Optimization from Photovoltaic	Integrated solar thermal control	Wi-Fi Remote Control	Anti Legionella Sanitization	Scheduling	Smart grid	Active defrost

MODEL		200 HT	260 HT
Nominal storage capacity	L	192	250
Max. hot water capacity at 40°C	L	260	358
Storage dispersion	W	60	70
Max. DHW temperature with heat pump only	°C	62	62
Max. DHW temperature with supplementary electric booster	°C	75	75
Integrated heating element power	W	1500	1500
Average absorbed power in heating	W	370	370
Heat output from pump	W	1248	1283
Dimensions (∅ x H)	mm	621 x 1607	621 x 1892
Empty weight	kg	86	98
Max. water pressure	bar	7	7
Max. air temperature	°C	43	43
Min. air temperature	°C	4	4
Nominal air flow	m ³ /h	350	350
Cold air outlet max. available head	Pa	100	100
Duct diameter	mm	160	160
Required room volume	m ³	>20	>20
Power supply parameters	V-Hz	230V - 50Hz	230V - 50Hz
Protection rating		IP24	IP24
Indoor sound power Lw(A)	dB(A)	52	52
Gas type		R134a	R134a
Charge quantity	g	1000	1000
Heating time 7°C in ECO mode	hh:mm	07:16	09:44
COP		2.8	3.1
Internal coil for solar		--	--
Energy efficiency class for heating water in average climatic conditions			
Water heating energy efficiency % in average climatic conditions	%	116	127
Annual energy consumption in average climatic conditions	kWh	883	1315
Declared load profile		L	XL



The illustrations and data provided are indicative. Lamborghini CaloreClima reserves the right to make any changes deemed to be most appropriate for the improvement of the product or of the service offered without being obliged to give prior notice.

The images in this catalogue are under copyright owned by Lamborghini CaloreClima.

cod. 89AG5037/04 - Ed. 05-2026